

The Monitoring System of Soil PH Factor Using IoT-Webserver-Android and Machine Learning: A Case Study

Sumarsono^{a,*}, Fatma Ayu Nuning Farida Afiatna^a, Nur Muflifah^a

^aDepartment of Industrial Engineering, University of Hasyim Asy'ari Tebuireng Jombang, Jombang, East Java, 61471, Indonesia
Corresponding author: *sonsumarsono13@gmail.com

Abstract— In Indonesia, the agriculture industry has been more reluctant than other sectors to adopt IoT, IT, and AI technology. Utilizing this technology will enable precision agriculture. This research aims to make and implement an IoT-Webserver-Android and Machine Learning-based soil PH factor monitoring tool system. The steps for making the tool system are divided into three subsystems. The first is a multiple sensors data acquisition subsystem, consisting of sensors for soil PH-Moisture, Temperature-Humidity, and Sunlight. The sensors are connected to the Arduino Uno microcontroller for serial communication with the ESP 8266 microcontroller for the Wi-Fi module. The second part is the monitoring subsystem with the local web application, which contains a MySQL database and a local web page. The third part is the monitoring subsystem with the Android application, which includes a real-time Firebase database and the application for real-time and mobile data display. The results have been implemented and display the expected outcomes. It is clear from the performance of the three subsystems. The outcomes of the tool system's data evaluation provide precise statistical values. Then, Machine Learning analysis generates accurate soil PH prediction models. It has been demonstrated that the monitoring system is applicable and has a favorable impact on data soil PH factor. The implication for the future is that this monitoring system should be added with Nitrogen-Phosphorus-Potassium sensors to measure soil nutrients. Also, the system added edge-analysis to be integrated in monitoring and analyzing soil nutrients.

Keywords— IoT-agriculture; IoT; webserver; Android-ML; monitoring system; soil PH factor.

Manuscript received 3 Mar. 2023; revised 8 Nov. 2023; accepted 4 Jan. 2024. Date of publication 29 Feb. 2024.
IJASEIT is licensed under a Creative Commons Attribution-Share Alike 4.0 International License.



I. INTRODUCTION

In Indonesia, agriculture enterprises are prevalent. Agriculture is one of the top three industries in terms of economic contribution and employment. Research results [1] Agriculture contributes 10% to exports, processing businesses 88%, and other sectors 2%. Most business locations are in rural areas close to agricultural sources as business raw materials are based on geography and demographics. Furthermore, according to [2], it is predicted that Indonesia's population will almost double to 262 million people over the past four decades. Then, demographic and climate changes pose challenges to food security in the future. It shows that sustainability must be one of the priority agendas in the agricultural planning of the country. Indonesia must continue to increase food production while preserving natural resources, especially soil and water.

According to earlier authors' research, agricultural enterprises still lack the supply chain competitiveness of other industries like manufacturing and trading. The information

component is the farm industry's vulnerability, particularly at the trim business level [3]. Meanwhile, small and medium-sized firms are beginning to use information technology. Managed back then with manual labor and traditional technology [4]. Considering that it is still manual and conventional. The execution of agricultural tasks is frequently erroneous or inaccurate, such as overfertilization and vice versa. This occurred due to the lack of accurate and current soil parameter data. Another illustration is using pesticides or insecticides to eradicate insects or other pests. It has not always been successful. Because of the negative consequences on the ecosystem [5]. These few instances highlight the limitations of agricultural management using manual technology, which cannot deliver precise processes and outcomes. Therefore, the solution calls for the use of technology, such as the Internet of Things (IoT) in agriculture, to facilitate operations and produce more precise results, and do so with low installation costs [6], [7].

The Internet of Things (IoT) enables seamless possibilities for information, goods, and money to travel between

agricultural organizations [8]. IoT is the interconnection of devices like tools, machines, and objects with the internet so they may operate on their own without human involvement [9]. Numerous studies on the use of IoT technology in agricultural enterprises have demonstrated that it improves the efficiency of farmers and machinery. IoT improves efficiency by shortening cycle times and labor requirements. Then, develop responsiveness through control, automation, and real-time data. Several earlier research, including [10], [11] IoT implementation using fog computing and LoRa Wi-Fi in rural areas. [12] IoT and cloud android are being used to access agriculture parameters. [13] use of multiple sensors and Cloud-IoT applications for Intelligent Farming System. [14] using IoT for precision irrigation, and [15] using green IoT for agricultural monitoring systems. [16] utilizing a combination of artificial intelligence (AI) and hardware (Wireless Sensor Networks), software (Software Define Network), and analytical techniques (Machine Learning) to agricultural management.

It is impossible to separate the use of IoT for precision agriculture from the analysis and monitoring of the data supplied by IoT devices. Therefore, the data analysis process becomes an essential component of precision agriculture. Widespread data analysis approaches include Machine Learning, which plays a crucial role in IoT-Agriculture analysis [17]. Precise outcomes are vital for agriculture. Due to the current state of uncertainty. Where it is subject to weather and environment variations, such as temperature, precipitation, and humidity, which can cause severe crop damage. Therefore, it is essential to improve the precision of data analysis from IoT-Agricultural device. Moreover, the properties of big data IoT-Agriculture's (large volume, veracity, and velocity) present a difficulty for data analysis [18], [19]. Several studies on the application of data analysis using Machine Learning in IoT-Agriculture for precision agriculture. Such as [20], Machine Learning is able to examine large datasets by arranging vast amounts of data. Additionally, it can reveal hidden patterns and relationships in data [21]. The outcomes of the data analysis can be applied

to the detection of plant diseases (Suhag et al., 2021), identify and manage weeds [23], [24], also smart irrigation [25], [26]. In addition, it can operate a soil fertility monitoring system [22], [27].

The focus of this article's IoT-Agriculture application is to make and implement a soil Ph factor monitoring tool system. Soil is a significant component of agricultural output. The soil provides the plant with nutrients required for growth. Several environmental and chemical soil components have a substantial impact on soil fertility and crop yields. Environmental factors including temperature, humidity, and ambient light. Soil chemical components include soil PH and Moisture. In addition to nutrients, soil fertility is also controlled by conditions that limit plant growth. Such environmental variables as temperature, humidity, and sunlight, as well as soil PH and soil moisture, must be monitored for precision agriculture [28]–[30]. In addition, soil PH, soil moisture, temperature and humidity, and sunlight create productive soil nutrients.

This article describes the findings of an IoT-Webserver-Android based monitoring system for soil PH factors. Then, analyze the data using Machine Learning. This article is distinct from past research papers. The distinction is in the subsystems, such as (1) multiple sensors data capture with simultaneous usage of four sensors and serial connection between two microcontrollers. (2) The subsystem monitors the soil PH factor on local web application, which stores data in the Mysql database and shows values and graphs in real-time on the local web. Moreover, (3) monitor subsystem using an Android application that displays data on mobile devices in real-time. Then, perform Machine Learning analysis with multiple algorithms to obtain the most accurate model for predicting the soil PH factor. Where soil PH factor metrics concentrate on soil moisture, temperature, humidity, and sunlight.

The following is an overview of the flow framework from the article "The Monitoring System of Soil PH Factor by Using IoT-Webserver-Android and Machine Learning: A Case Study".

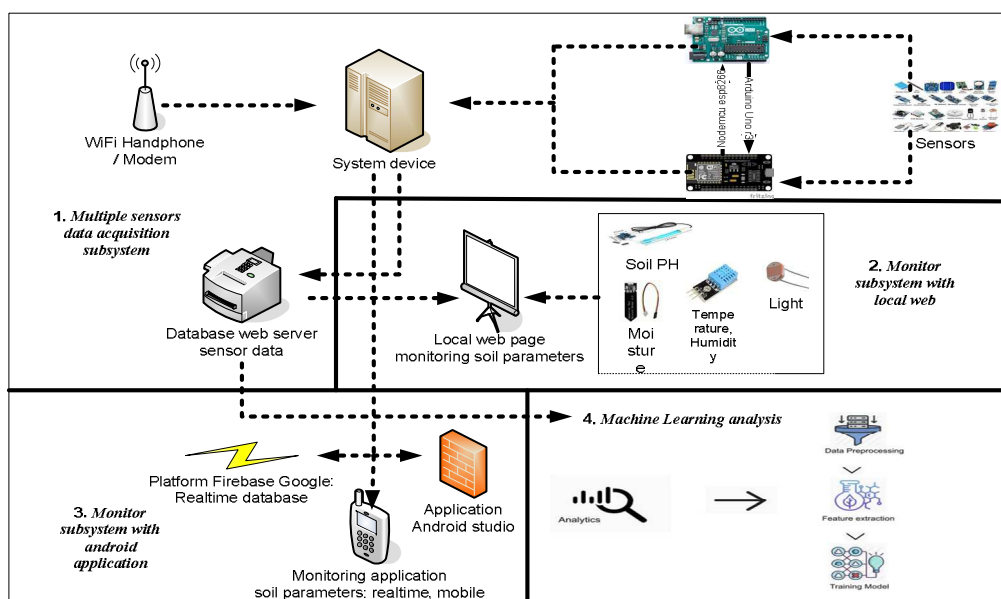

Fig. 1 The flow framework

II. MATERIALS AND METHOD

The primary purpose of the research is to make and implement an IoT-Webserver- Android based soil PH factor monitoring tool system. The data is then analyzed using several Machine Learning algorithms. Then, select the best accurate prediction algorithm model. To achieve the goals of the research, many different actions have been conducted. The creation of a system for monitoring tools after multiple experiments. Then go ahead and gather and evaluate data in the fields. Figure 2 shows a complete illustration of a system diagram for a monitoring and analysis tool.

Four steps can be seen in Figure 2, including three tool subsystems and one analysis stage. (1) Multiple sensors data acquisition subsystem; (2) monitor subsystem with local web of soil fertility_“http://localhost/sensortanah/”; (3) monitor subsystem with android application "soilMonitoring"; (4) Predictive analysis of soil PH factors with several Machine Learning algorithms. The response variable, which is soil PH as an indicator of soil fertility. Then soil moisture, temperature, ambient humidity, and sunlight are among the predictive variables.

Making a tool system prototype is a component of research design. The primary data from the study's sample population with the focus on fields with different rice, corn, and sugarcane plant species. Specifically, data sampling was done in the Jombang Regency in East Java and the Sukoharjo

Regency in Central Java. As samples, there are 19 different field locations. In the fields, sampling was done twice, in the morning and in the afternoon. It's between 04:45 - 05:45 in the morning and between 13:30 - 14:30 in the afternoon. Due to the distinction between morning and afternoon time to indicate the variations in temperature, humidity, and sunlight.

Collecting data in the fields were using a Wi-Fi internet of Smartphone. Power from the power bank is used to power the appliance system. After that, the sensors will be controlled by the Arduino uno r3 microcontroller. The Esp8266 nodemcu v3 microcontroller will simultaneously be connected to Wi-Fi in order to carry out serial communication tasks with the Arduino uno r3. After that, data to the MySQL database. The aforementioned procedure takes place in subsystem 1, after which it is simultaneously transmitted to subsystems 2 and 3. In subsystem 2, the MySQL database houses the sensor data. As seen in Figure 3, the numbers and graphs are then displayed on the local web page for monitoring. Additionally, the firebase real-time database in subsystem 3 receives sensor data from subsystem 1. The illustrations are shown in Figure 4-a. Google offers a cloud database platform called Firebase database. The Android application will display sensor data sent by this platform. Displaying sensor results and the soil PH status, which serves as a measure of soil fertility, like in Figure 4-b. Next figure 5, depicts the monitoring tool system's display when it is being utilized in the field. The interior of the tool is depicted in Figure 5-a. Figure 5-b depicts the tool's exterior.

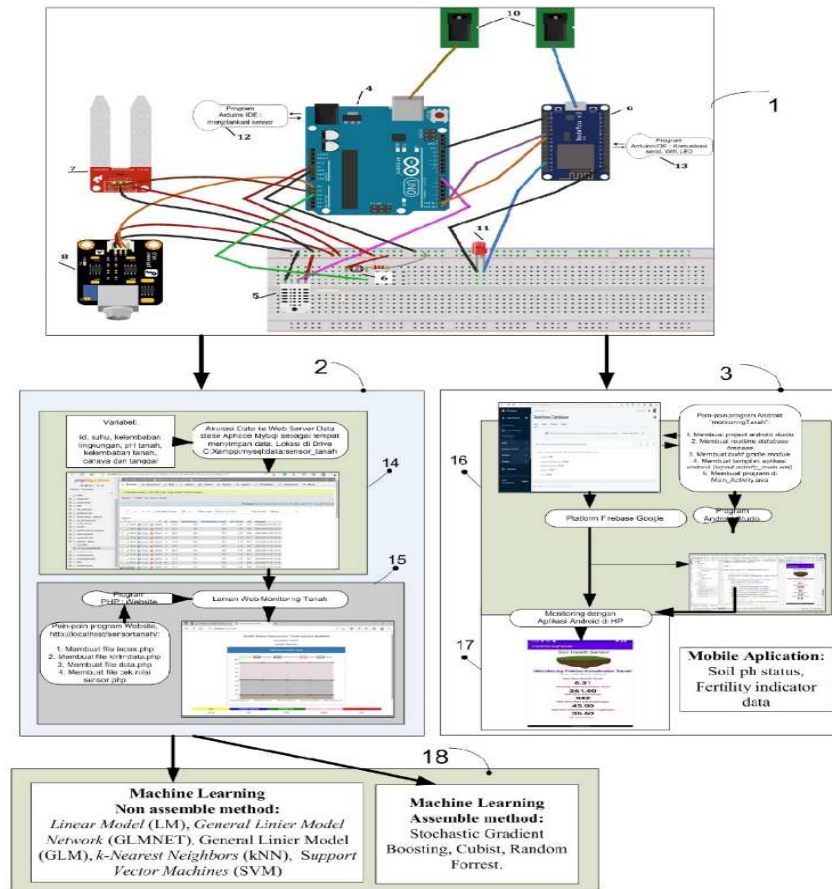

Fig. 2 Diagram of the system for soil fertility monitoring based IoT-Webserver-Android and machine learning analysis

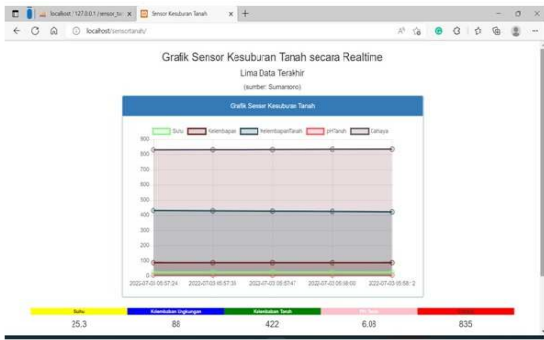
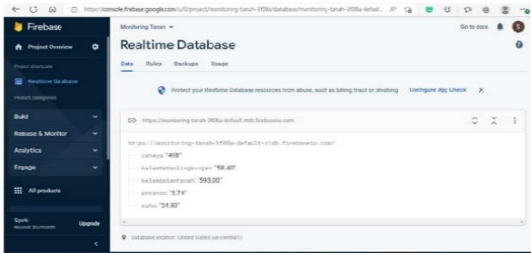

Fig. 3 Local web monitoring page



(4a)



(4b)

Fig. 4 (a) Real-time database view for Firebase; (b) Android smartphones show sensor values

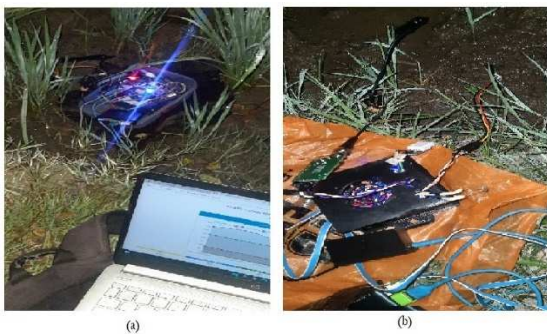

Fig. 5 (a) The tool view looks in; (b) the external view of the tool

III. RESULTS AND DISCUSSION

A. Multiple sensors data acquisition subsystem

Figure 2 in item number 1 displays the succession of operational configurations of the multiple sensors data acquisition subsystem. The initial component is this subsystem. The first microcontroller in the system, the Arduino Uno r3 (number 4), which serves as a hub for the management of sensors, is where the system's operational

procedure is controlled [31]. This microcontroller is programmed to read, display sensor values, check the Wi-Fi connection, capture, and respond to send data to an Esp 8266 Nodemcu v3. The Arduino Integrated Development Environment (IDE) is used to upload program content (number 12). The DHT22 temperature sensor (number 5), the LDR light + 5K1 resistor (number 6), Capacitive soil moisture sensor (number 7) and DIY More soil ph sensor (number 8) are all connected to this first microcontroller circuit. In addition, it is serially connected to a second microcontroller, Esp 8266 Nodemcu v3 (number 9) for the Wi-Fi module [32]. This second microcontroller serves as a transmitter, transmitting data from multiple sensors to subsystems 2 and 3. As a power supply using a power bank (number 10).

Following the function is a succession of subsystem 1 components. Beginning with the DHT22 sensor (number 5), there is a digital sensor for the ambient temperature and humidity [21], [33]. This sensor generates a calibrated reading. Using a capacitor and thermistor, the DHT22 sensor measures the surrounding air and outputs a signal to a pin. Specifications operate on a 5 voltage with a humidity range of 0 - 100% and a digital output. The DHT22 sensor is connected with Arduino Uno r3 via a Positive pin (+) to 5V; pin Out to D7; Negative pin (-) to Gnd.

The LDR sensor + the 5K1 resistor (number 6) constitutes a light sensor [34], [35]. One of the resistor's components whose resistance value varies with the intensity of the light. The greater the sensor value, the brighter the illumination. A circuit connects the LDR + 5K1 resistor sensor to the Arduino Uno r3; the first leg of the LDR sensor is connected to the 5K1 resistor, which is connected to the Gnd pin of the Arduino Uno r3. The first leg of the LDR + resistor 5K1 sensor is also connected to pin A2 on the Arduino Uno r3. The second leg of the LDR sensor is then connected to the Arduino Uno r3's 5V pin.

The capacitive soil moisture sensor (number 7) is an analog sensor that operates to measure soil moisture [36], [34]. Analog values range from 0 - 1023. The sensor operates using the capacitance concept. As a result of being painted with PCB paint, the PCB is rendered rust resistant. This sensor is connected to Arduino Uno r3 using a circuit consisting of the following pin connections: Gnd to Gnd, Vcc to 5V, and Aout to A1.

DIY more soil ph sensor (number 8) [37], [38]. This sensor consists of both a PH module and a probe. The data is issued in analog 0-1023 format. Therefore, it must be calibrated by switching to the voltage value and then the PH value of the soil. The calibration formula for converting sensor value to voltage is [sensor value PH x (5.0 / 1023.0)] - 0.07. Then it is transformed to the soil PH value with the formula, PH value = (-3.429 x stress) + 16,714. Circuit schematic is connected to Arduino Uno r3 via pin V+ to 5V; pin G to Gnd; pin Po to A0.

The second microcontroller, Esp 8266 Nodemcu v3 (number 9), is an electronic board module that operates as a WiFi connection and is based on the Esp 8266 chip [39]. This microprocessor manages data requests from the first microcontroller, as well as data transmission to subsystems 2 and 3. The second microcontroller contains a number of input output pins that will be connected to the first Arduino Uno r3 microcontroller, the power bank power source (number 10), and the LED lights (number 11). When the LED light





illuminates, it indicates a connected internet network. The contents of the program on the second microcontroller are serial data communication with Arduino Uno r3, Wi-Fi connection and LED actuator. Then the compiler program uses the Arduino Integrated Development Environment (Arduino IDE) as shown in number 13.

The Arduino IDE program uploaded to the initial Arduino Uno r3 microcontroller (number 12) consists of three major sections [34]. The initialization section activates library: Wi-Fi, DHT22 sensor. It also defines variables: Wi-Fi (SSID, password), DHT22 sensor, and sensors values. Next displaying serial monitors, activating the DHT22 sensor, and initializing the hostname and Wi-Fi connection are included in the two application configurations. The three program loops display sensors values on the serial monitor by repeatedly executing commands including commands to read sensors information. If there is a connection between Esp 8266 Nodemcu v3 and the website. Then sensor data will be sent. Next, the command captures the answer to data requests from Esp 8266 Nodemcu v3.

In addition, the contents of the program in the Arduino IDE for the second microcontroller Esp 8266 Nodemcu v3

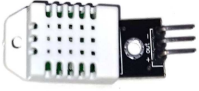
(number 13) are comprised of three primary sections. The first comprises libraries from Esp 8266, Firebase, Wi-Fi, arduinoJson, and softwareSerial; variables for connecting to google realtime firebase; construct variables: LED pins, softwareSerial, parsing data arrays, and “delay” replacement “millis”; establish a variable to accommodate sensor values on the web server, as well as a WiFi variable (SSID and password). The second section is a setup application that includes a serial monitor display and serial data; configuring LED pin, hostname, checking WiFi and firebase connectivity. The third is a form of looping that contains the command to repeat program requests in the form of a “millis” configuration command as a replacement for “delay” as a delay in receiving sensor data. Next, command to read serial data from the Arduino Uno v3 microcontroller and confirm that the data is complete. Then, data variable directives to be transmitted to subsystems 2 and 3; Create and execute a webserver URL link variable to transfer data; the command records the response to send data from the Arduino Uno v3 microcontroller. The command repeatedly requests data after a delay of at least 12 seconds. More information to clarify the relationship between subsystem 1 components in Table 1.

TABLE I
RELATIONSHIPS BETWEEN COMPONENTS IN SUBSYSTEM 1

No	The Components	Relationship between components
1.	Microcontroller Arduino Uno r3. 	This microcontroller will connect with DIY more soil PH, Capacitive soil moisture, DHT22 temperature, LDR light + 5K1 resistor
2.	Temperature sensor (DHT22) 	DHT22 sensor connected with Arduino Uno r3 <u>Arduino Uno r3</u> <u>DHT22</u> Pin 5 V + Pin D7) Out Gnd -
3.	LDR + resistor 5K1 sensor 	LDR + resistor sensor connected with arduino uno r3 <u>Arduino uno r3</u> <u>LDR + resistor 5K1</u> Pin Gnd Resistor 5K1 → kaki 1 LDR Pin A2 Leg 1 LDR Pin 5 V Leg 2 LDR
4.	Sensor Capacitive Soil Moisture 	The capacitive moisture soil sensor connected to the Arduino Uno r3 <u>Arduino Uno r3</u> <u>Capacitive soil moisture</u> Pin Gnd Gnd Pin 5V VCC Pin A1 AOOUT
5.	DIY More soil PH sensor 	Diy more soil ph sensor connected with Arduino Uno r3 <u>Arduino Uno r3</u> <u>Soil ph</u> Pin 5 V V+ Pin Gnd G Pin A0 Po
6.	Microcontroller Esp 8266 Nodemcu v3 	Esp 8266 Nodemcu v3 connected with Arduino Uno r3 and LED <u>Arduino Uno r3</u> <u>Esp 8266 Nodemcu v3</u> Gnd Gnd Rx D7 Tx D6
		<u>Esp 8266 Nodemcu v3</u> <u>LED</u> D2 + Gnd -
7.	Power Bank	The Power Bank is connected with a USB cable to Esp 8266 Nodemcu v3. Likewise is connected to the Arduino Uno r3.

B. Monitor Subsystem with Local Web <http://localhost/soilsensor/>

The stage after data collection is then displayed on the second subsystem's local website. Illustration corresponding to Figure 2 in number 2. This subsystem consists of two major components: data acquisition to the MySQL database webserver (number 14) as a place to store sensor data [39]. The second section of the website for local soil PH factor monitoring (number 15). Displays the most recent data value and the time series graph of the most recent five data. The displayed information consists of soil PH, soil moisture, environmental temperature-humidity, and sunlight.

Subsystem 2 employs the XAMPP application for the web developer application [40]. XAMPP is open-source software based on a web server that is compatible with Windows, Linux, Mac, and Solaris. XAMPP is an acronym comprised of five characters that stands X for "Cross platform" and may run on a variety of operating systems. In addition, A is for "Apache," a web server application that serves as a source for developing PHP-based web pages. M for MySQL is a database server application that uses the Structured Query Language (SQL) programming language to administer, develop, and organize a structured and systematic database system. Next, PHP is a server-side web-based programming language denoted by the letter P. So that it can be utilized to create more dynamic website pages. In addition, the letter P for "Perl" represents a programming language for multiple operating systems; therefore it is adaptable.

The MySQL database stores seven variables, including the data identification number, temperature, environmental humidity, soil pH, soil moisture, sunlight, and the data collecting date. The data is then shown on the website page as values and time series graphs. Making web pages with PHP. PHP is a web application development framework [41].

The procedure for developing a website page entitled "Monitoring Soil Fertility" in subsystem 2 is as follows.

- Text Editor programming language using *Sublime Text*.
- Setting up a "soilsensor" template file in the XAMPP/htdocs folder containing css type files, fonts, igm and js type files.
- When creating an index.php file with the *Head:* command, the bootstrap file, data to display graphically and sensor values are called.

Then, the body displays the data in the form of graphs and sensor values.

- Create a connection to the "soil fertility factors" database in the "senddata.php" file. This file records data from the Mysql database.
- Create a file named data.php that will be called index.php to display the time series graph. The content of the data.php program consists of commands: (1) Connection to the database "soil fertility factors" and read the variables, (2) Reads and shows graphs comprising information on "date", "temperature", "environmental humidity", "soil moisture", "soil PH", and "sunlight".
- Create a PHP file to check the sensor values, which index.php will call to display the sensor values on the Web page. This PHP file checks the sensor values for soil PH-moisture, ambient temperature-humidity, and

sunlight. The program's contents in the form of a command: (1) Connect to the "soil fertility factors" database and retrieve the variables, (2) The most recent data values are "temperature", "environmental humidity", "soil moisture", "soil PH", and "sunlight."

Before being displayed in a web browser <http://localhost/soilsensor/>. First, activate the "apache" and "mysql" modules in the XAMPP control panel application.

C. Monitor Subsystem with Android Application "soilMonitoring"

Subsystem 3, use an android application to monitor the soil PH factor, as depicted in Figure 2 number 3. Android apps even if the internet connection is unstable. It is possible to monitor processes. As a location for data storage utilizing Google's Firebase technology. Firebase by Google is a free cloud service with a huge storage limit [42], [43]. In addition, cloud services are convenient and adaptable. Because it is mobile-accessible.

Subsystem 3 consists of two major components, the first of which is Google's firebase platform for data collecting (number 16). This section provides an Android application with a real-time database. The second section is a monitoring application for android applications (number 17). This section provides details on the soil's PH level and sensors values.

This is the procedure for developing an android application using the android studio software.

- Create the "soilmonitoring" Android Studio project. Ensure that your computer or laptop is online for "gradle" synchronization.
- Connect the Realtime Database Firebase to the Android Studio project. How to establish a firebase database at firebase.google.com using the Google email login. Create a new project on console.firebase.google.com called "soilmonitoring" after that.
- After establishing a connection to the Firebase database, use Android Studio to construct a "Build Gradle Module".
- Make the display of the android application layout "soilmonitoring" in "activity_main.xml".
- Create an android application-readable real-time database in Firebase. The sensor measurements of soil PH, soil moisture, temperature, humidity and sunlight level are transformed into variable values.
- Return to the Android studio application to create a program by opening "main_activity.java". This program displays sensor values from Firebase realtime database.

D. The Stage of Data Review Produced by the Monitoring System

Evaluation of the data's precision based on the results of the monitoring tool by testing the multiple sensors data. Evaluation by understanding the precision and interpretation of the multimodal field data produced by the system. According to [44], it will be challenging to employ multiple sensors in the same location. As a result of intersensor "crosstalk". For this reason, they conducted multiple sensors tests with hot and cold locations. Exists any distinction between the two conditions. Then, whether multiple sensors function independently and do not influence one another.

To determine whether each sensor is functioning properly “no crosstalk” by assessing the accuracy of each sensor's data. The statistical descriptive numbers, notably the mean and median, reveal the accuracy of the data. The standard deviation value and the symmetry of the data follow. If the mean and median values are comparable; low standard deviation; symmetrical data set. The monitoring system then generates data collection with precise properties. This indicates that the system generates consistent and stable data. In other words, the monitoring tool system has been operating as expected.

The results of the field survey yielded 5291 data points. To depict conditions during the day. The retrieval of data occurred at two distinct periods. During the hours of 04:45 to 05:45 in the morning, temperatures are low. The afternoon is then between 13.30 and 14.30, when the temperatures are high. Each time group's descriptive statistical values were evaluated. Table 2 displays the findings of descriptive statistics from field data collected by multiple sensors in the morning and afternoon.

TABLE II
MORNING AND AFTERNOON FIELD DATA STATISTICAL VALUE

Statistics			Soil PH (0-14)	Soil Moisture (0-1023)	Humidity (%)	Temperature (°C)	Sunlight level (0-1000)
Morning (n = 2461)	95% Confidence Interval for Mean	Mean	5.59	431.33	75.84	29.01	485.82
		Lower Bound	5.57	424.94	75.18	28.76	475.08
		Upper Bound	5.62	437.73	76.50	29.25	496.57
		Median	5.84	389.00	82.00	29.50	529.00
		Std. Deviation	0.71	161.75	16.63	6.13	271.83
		Skewness	-0.929	1.139	-0.463	0.259	-0.168
		Mean	6.17	313.32	67.44	31.41	958.64
Afternoon (n = 2830)	95% Confidence Interval for Mean	Lower Bound	6.14	310.13	66.66	31.11	956.22
		Upper Bound	6.19	316.50	68.22	31.71	961.06
		Median	6.09	272.00	60.00	29.00	973.00
		Std. Deviation	0.60	87.40	21.46	8.29	66.51
		Skewness	5.226	1.674	0.015	0.390	-5.317
		Mean	6.17	313.32	67.44	31.41	958.64
		Morning vs. Afternoon	Sig. t-independent	0.00	0.00	0.00	0.00

1) Soil PH field data values

The value of the soil PH field data is generated from the soil PH sensor in the form of analog values. This amount is changed into a voltage amount. Then it is transformed to a PH value that is worth between 0 - 14. Based on the calibration equation obtained, the value of $PH = -3.429 \times \text{voltage} + 16.714$. Where voltage value = {sensor analog value x (5.0/1023)} - 0.07. The soil PH measurements taken in the field in the morning and afternoon demonstrate excellent precision. The average and median values are comparable. Morning time by means; median (5.59; 5.84), then afternoon (6.17; 6.09). Furthermore, the 95% confidence interval for mean of the soil PH is between 5.57 – 5.62 (morning) and 6.14 – 6.19 (afternoon). Both intervals have small values. This shows the precise value of the soil PH. The tiny standard deviation of the soil PH values, namely 0.71 in the morning and 0.6 in the afternoon, demonstrates the same conclusion. Moreover, the symmetrical shape of the data indicates the precision of the data. Morning skewness is -0.929 and afternoon skewness is 5.23. Where the number is close to zero in the morning and remains reasonably low in the afternoon.

The interpretation of field data values for soil PH reveals the neutral category in the afternoon and the nearly neutral category in the morning. The PH of the soil is neutral at 6-7, with acid below 6 and base above 7. In fields, there is a difference in the soil's PH value in the morning and afternoon.

This is demonstrated by the results of the independent t-test between morning and afternoon, where the probability < 0.05 (Sig. t-independent = 0.00). This finding is in line with [45], The soil PH sensor's reading will be impacted by temperature conditions. The appearance of various results at different temperatures implies the sensor has been working successfully. Another explanation is that there is typically no evapotranspiration in the morning, and soil moisture is still low. And vice versa happens in the afternoon. This assertion is consistent with [35], which states that temperature affects evapotranspiration and soil moisture, which in turn affects soil PH.

The level of soil fertility is closely related to the PH value of the soil [35]. Because the neutral and unneutral PH of the soil impacts the ease of absorption of nutritional ions by the soil. When the PH level is between 6-7, soil is considered to be fertile (neutral). Where nutrients will easily dissolve in the soil. Certain soil PH levels can also indicate the presence of toxins in the soil. In order for the soil PH to become neutral. Therefore, fertilizer is required to lower or raise soil acidity. Lime can be utilized to raise the soil's PH. While sulfur is employed to inhibit acidity.

2) Soil moisture field data values

The soil moisture sensor outputs an analog value for field data from soil moisture (1 – 1023). According to [46], [36] sensor capacitive soil moisture, the analog value category $<$

350 is damp or wet. Values between 350 - 700 are considered typical, whereas values > 700 indicate a dry environment. The sensor's value will decrease as soil moisture increases. As a result of water resistance, the sensor's voltage reading will drop, and vice versa. The survey findings for morning and afternoon provide a precise figure for soil moisture. When the median and mean are of equal relative importance. Morning by mean and median (431.33; 389.00), followed by afternoon (313.32; 272.00). The soil moisture value of 95% confidence interval for mean from 424.94 to 437.73 in the morning and 310.13 to 316.50 in the afternoon. The fact that the values' range is still narrow suggests precision. Moreover, based on the 161.75 standard deviation for the morning and 87.40 for the afternoon. The symmetrical shape of the data will then reveal the precision of the data. Because they are nearly 0. The values of 1,139 (morning) and 1,674 (afternoon) for skewness.

According to the interpretation of the value of field data from soil moisture, the morning moisture level is within the normal range. while being in the humid category during the afternoon. This occurred as a result of the farmers' practice of irrigating the fields throughout the day at the survey site. Such that the soil is generally more humid during the day than it is in the morning. The outcomes of independent t-testing on field data also support this. Soil moisture conditions in the morning and afternoon were significantly different (Sig. t-independent = 0.00). The sensor has performed successfully because there is a difference in sensor values between the morning and the afternoon. Because the land has water and vice versa [47]. On the other side, knowledge of the soil's moisture content can help farmers make less mistakes [48]. One of the elements that influences soil fertility is the amount of water in the soil [49]. Because it keeps the soil's temperature constant while serving as a vehicle for plant nutrients in order for plants to flourish.

3) Humidity and Temperature field data values

The range of the DHT22 digital sensor's humidity field data is 0 - 100%. The figure that is higher indicates that the air around the soil is more humid. The humidity value in the morning and afternoon survey results indicate a precision value. Since the mean and median have the same relative value, it is known. By mean and median (75.84; 82.0), morning time is followed by afternoon (67.44; 60.0). A total of 95% Confidence interval for mean of the humidity values between 75.18 - 76.50 (morning) and 66.66 - 68.22 (afternoon). The fact that the values' range is still narrow suggests precision. Moreover, based on the 16.63 standard deviation for morning time and 21.46 standard deviation for afternoon time. Furthermore, the symmetrical shape of the data indicates the precision of the data. Morning skewness is -0.463, and afternoon skewness is 0.015. Because they are nearly 0, these values.

Furthermore, the DHT22 digital sensor with °C units is used to generate temperature data. A precision value can also be seen in the morning and afternoon temperature field data findings. Based on mean and median values with the same relative weight. Morning time by mean; median (29.01; 29.50), then afternoon (31.41; 29.00). The Confidence Interval 95% for mean of the temperature values are between 28.76 - 29.25 (morning time) and 31.11 - 31.71 (afternoon

time). The narrow range of results is indicative of precision. In addition, the morning standard deviation was 6.13 and the afternoon standard deviation was 8.29. Additionally, the symmetrical structure of the data reveals the accuracy of the data. Morning skewness is 0.259 while afternoon skewness is 0.390. Because these values are close to 0.

The interpretation of the humidity and temperature data reveals that the sensor's average value in the morning is 75.84% and 29.01°C. Then in the afternoon 67.44% and 31.41°C. This figure indicates that morning humidity is higher than afternoon humidity. This occurs because the morning temperature is lower than the afternoon temperature. The outcomes of independent t-tests on field data demonstrate this discrepancy. If there is a significant difference between the humidity-temperature in the morning and the afternoon (Sig. t-independent = 0.00). Therefore, it has been demonstrated that the DHT22 sensor's results for measuring humidity and temperature in the surroundings are precision. This statement is in line with [33], [50], DHT22 sensor has high reliability.

The data on ambient humidity and temperature are crucial for agriculture. Reduced agricultural yield will result from irregular weather changes [51], [52]. In addition, the humidity-temperature is a characteristic that maintains the soil warm for living creatures. The ideal temperature for soil organisms is around 25-35°C. Moreover, the humidity-temperature is also affected by height. Humidity and temperature will decrease with each 100 meters. Where the air temperature will drop to approximately 0.61 °C.

4) Sunlight level field data values

The value of the sunlight field data collected by the LDR sensor + 5K1 Resistor whose value varies with the light brightness. So that it can function as a light sensor. The greater the light intensity, the greater the sensor value [9]. The findings of field surveys conducted in the morning and afternoon demonstrate the precision of the light sensor. It relies on the mean and median, which are comparable measures. Morning time by mean; median (485.82; 529.0), then afternoon (958.64; 973.). The Confidence Interval 95% for mean of the sunlight level is between 475.08 - 496.57 (morning) and 956.22 - 961.06 (afternoon). A narrow value range shows precision. Moreover, based on the morning standard deviation of 271.83 and the afternoon standard deviation of 66.51. It is also relatively low. Furthermore, the precision of the data may also be recognized from the symmetrical shape of the data. The skewness value is -0.168 (morning), which is close to zero. Then the value of skewness is -5,317 (afternoon), which remains reasonably low in the afternoon.

The evaluation of the sunlight level data reveals that the average sensor value in the morning is 485 and, in the afternoon, it is 956. If one considers the vast disparity. When there is a variation in the amount of light produced by the sensor, it appears to be genuine. This is further supported by the significantly different results of the independent t-test (Sig. t-independent = 0.00). Therefore, it has been established that the LDR sensor + 5K1 resistor has operated effectively. This result is in line with [53], LDR sensors and resistors are capable of measuring light levels.

The effect of sunlight on soil fertility is significant. Because the amount of sunshine has a close relationship with

the environment's temperature and humidity [54]. It helps sustain the soil's warmth and the existence of healthy organisms.

E. Step of Data Analysis Utilizing Machine Learning

The MySQL database houses the data that the tool system has collected. A total of 5291 observational data were gathered as a consequence of field data collection. The phases of predictive analysis using the Machine Learning technique and R Packages-Caret. The full sequence of steps is as follows:

- Opens the Rcmdr library for data importation. The dependent variable included in the research data is the soil PH. Temperature, ambient humidity, soil moisture, and light then constitute the independent variables.
- Enable library: "Caret; lattices; ggplot2". Then activate the dataset to be analyzed, namely "soilprediction".

- Divide the data into dataset for training (80%) and dataset for validation (20%).

1) *Displays the training dataset's dimensions:* The resulting training dataset has 4234 rows of data and 5 columns of variables. Displays the type of the training dataset. The type of outcome of the five variables is numeric. Displays a brief summary of the training dataset. The results are in table 3. Based on the aforementioned training dataset's summary results. The average temperature is reported to be 30,4 °C, with a minimum of 19.8 °C and a maximum of 48.4°C. The average relative humidity is therefore 71.38%, with a minimum of 33% and a maximum of 97%. In addition, the average value of soil moisture is 364.4, with a low of 243 and a maximum of 908. The sunlight value ranges from 46 - 1001, with an average value of 745.4. Additionally, the pH level of the soil has a range of 3.76 to 7.45, with an average value of 5.89.

TABLE III
SUMMARY OF THE TRAINING DATASET

Value	Temperature	Humidity	Soil moisture	Sunlight level	Soil PH
Min.	:19.8	:33.00	:243.0	:46	:3.760
1st Qu.	:23.7	:54.00	:263.0	:572	:5.610
Median	:29.4	:71.00	:306.5	:931	:6.010
Mean	:30.4	:71.38	:364.4	:745.4	:5.897
3 rd Qu.	:36.2	:91.00	:430.8	:975	:6.310
Max.	:48.4	:97.00	:908.0	:1001	:7.450

2) *Estimating and evaluating Machine Learning Non-Ensemble method:* It is the algorithms included Linear Model (LM), General Linear Model Network (GLMNET), General Linear Model (GLM), K-Nearest Neighbors (kNN), Classification and Regression Tree (CART), and Support Vector Machines (SVM). The evaluation value of the non-ensemble algorithm model is calculated using the root mean square error (RMSE). According [55], the RMSE is the total of the squared root that are present between the predictions made by the model and the observation data. The RMSE helps

in transforming the squared error into the original units of predictions by taking the square root of the squared score [56], [57]. The calculation is shown in the following way.

$$RMSE = \frac{1}{m} \sum_{i=1}^m (Y_i - \hat{Y})^2 \quad (1)$$

Based on this formula, the smaller the RMSE value is, it approaches zero. It is concluded that the predicted value is similar to the observation data or accurate to predict. The comparison of RMSE values of several machine learning non-ensemble methods are shown in table 4.

TABLE IV
COMPARISON OF RMSE VALUES OF SEVERAL MACHINE LEARNING NON-ENSEMBLE METHODS

Models	RMSE					
	Min.	1st Qu.	Median	Mean	3rd Qu.	Max.
LM	0.491	0.505	0.516	0.518	0.532	0.558
GLM	0.491	0.505	0.516	0.518	0.532	0.558
GLMNET	0.491	0.506	0.516	0.518	0.531	0.558
SVM	0.171	0.191	0.207	0.207	0.224	0.237
CART	0.072	0.096	0.110	0.117	0.131	0.213
KNN	0.070	0.088	0.105	0.106	0.120	0.147

The KNN model with the smallest RMSEA value, with a mean value of 0.106. Additionally, for consideration, employ the assemble methods procedure. To determine whether it provides the most precise predictive value compared to the K-Nearest Neighbors (KNN) model.

3) *The estimation and assessment of the Ensemble methods:* Stochastic Gradient Boosting (GBM), Cubist, and

Random Forrest (RF) are the three models employed. Table 5 displays the results of the evaluation of the ensemble method using the root mean square error (RMSE). The comparison results indicate that the Cubist model is the most accurate. Because the smallest mean value is 0.082.

TABLE V
COMPARISON OF RMSE VALUE FROM ENSEMBLE METHODS

Models	RMSE					
	Min.	1st Qu.	Median	Mean	3rd Qu.	Max.
RF	0.051	0.067	0.080	0.084	0.097	0.140
GBM	0.155	0.165	0.179	0.177	0.185	0.198
CUBIST	0.051	0.065	0.083	0.082	0.098	0.144

4) *Determine the best Cubist model parameter values:* The least RMSE value indicates the ideal parameter value. Results indicate that Committee = 25 and Neighbors = 5 is the ideal value for the Cubist parameter. Because its RMSE value is the lowest. Figure 6 depicts the graph of the comparison of RMSE values among Cubist parameters.

5) *Using the most accurate model, Cubist with 25 committee and neighbors 5 parameters:* it aims to make predictions on the soil PH variable as an indicator of soil fertility using a validation dataset. The findings of the predictive value of soil PH and the accuracy of prediction are

shown in table 6. The results demonstrate a mean predictive value of 5.89, with minimum values of 3.74 and maximum values of 7.39. Where the level of precision as measured by RMSE is 0.104, which remains reasonably low. Because these values are close to 0. It is concluded that the predicted value is accurate to predict. This conclusion is also strengthened by the value of R-square is 97.7%, which is near to 100%. This implies that the predictor variable contributes 97.7% to predicting the response variable (soil PH). This number indicates that the Cubist model with parameters committee 25 and neighbors 5 is a fit model.

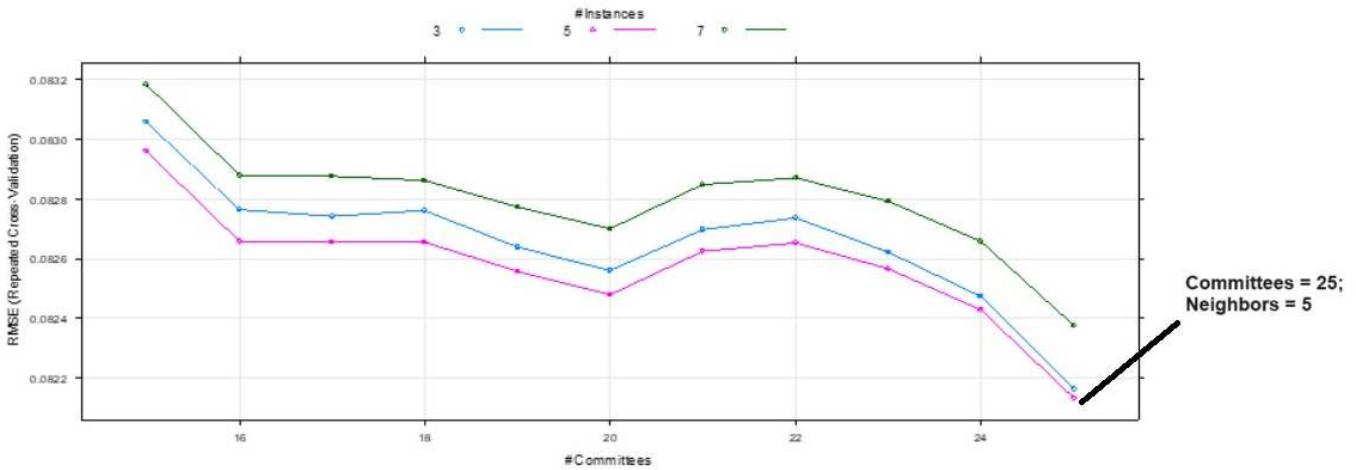

Fig. 6 RMSE comparison for some Cubist model parameters

TABLE VI
PREDICTION RESULTS OF SOIL PH VALUE AND PREDICTION ACCURACY VALUE WITH THE CUBIST MODEL COMMITTEES 25, NEIGHBOR 5 USING A VALIDATION DATASET

Summary Prediction of Acid Soil						Accurate	
Min.	1st Qu	Median	Mean	3rd Qu	Max.	RMSE	R Square
3.745	5.611	6.022	5.895	6.324	7.394	0.104	0.977

6) *Identify the importance of the predictor variable of soil PH Based on the selected model.* It could be done with the cubist model with parameters committees 25, neighbors 5, The outcomes are presented in Table 7. It is well established that soil moisture and temperature factors have the most significant effect on soil PH. Then changeable humidity and sunlight.

TABLE VII
CUBIST MODEL: VARIABLE IMPORTANCE

Predictors	Score
Soil moisture	87.5
Temperature	85.5
Humidity	62.5
Sunlight	60

F. The implementation of the monitoring tool system

The implementation of the monitoring tool system described in this article has produced satisfactory outcomes. The three subsystem processes of the tool system demonstrate their effectiveness. The first subsystem, a multiple sensors data collecting tool, has been able to collect soil PH-moisture, ambient temperature-humidity, and sunlight level data. The second monitoring subsystem with local web apps and the third monitoring subsystem with Android mobile phones have operated admirably. The entire system is capable of data storage, wirelessly presenting time series graphs and numbers, and remote sensing. Moreover, depending on the evaluation results of the system results data supplied previously. The monitoring instrument system has generated precise statistical values.

The obtained information is subsequently evaluated. A comparison of multiple machine learning methods revealed the best accurate soil PH prediction findings. Cubist model algorithm provides the most accurate model. According to [58], [59] The cubist model is a type of regression analysis that employs non-parametric machine learning techniques. Where this method is capable of revealing intricate nonlinear linkages. On the basis of the cubist model, it is concluded that soil moisture and temperature are the most influential determinants on soil PH. Then, humidity and sunlight follow. The findings are in line with the research [28], [29], [30] soil PH, soil moisture, humidity, temperature, and sunlight are crucial indicators that must be monitored in agriculture.

The implementation of soil PH factor monitoring system based on IoT-Webserver-Android and Machine Learning facilitates the achievement of precision agriculture. Utilizing IoT and IT to manage agriculture has a positive effect on information and agricultural yields. Because it can obtain large amounts of data, data in real-time, and precise predictions for understanding the behavior of soil PH factor. In addition, it is able to do autonomous monitoring procedures, graphical user friendly, conserve energy, and ability to operate for a long time. This assertion is consistent with the findings of prior research. Like research [60], deploying a Wireless Sensor Networks (WSN) multiple sensors monitoring system in rose farms. By analyzing environmental variables, mainly temperature, humidity, and light, the results found patterns of growth behavior in roses. Then [61] using IoT and Android applications for soil parameter monitoring (light, soil moisture, environmental temperature-humidity). The monitoring statistics indicate that the process is successful and efficient. Because the data is acquired in real-time, smartphones should feature user-friendly and mobile capabilities. Then the research results [62] using IoT to monitor agricultural environmental data (temperature and soil moisture). The results show that the data monitoring process becomes more efficient and precise. Research [17] create an IoT system, WSN data collecting and Machine Learning analysis techniques for disease prediction models in apple plants. The outcomes demonstrate precision, accuracy, data-driven, and intelligent agriculture. Other studies, such as research, have also demonstrated the same beneficial impacts, [63] show energy saving, [64] reduce soil matching errors to make the process more effective. Then, [30] ideas for sustainable and cost-effective agriculture.

IV. CONCLUSION

This research aims to make and implement an IoT-Webserver-Android and Machine Learning-based soil PH factor monitoring tool system. The soil PH factor includes soil moisture, humidity, temperature, and sunlight. This instrument system employs IoT, Webserver, and Android technologies. Then predictive analytic algorithms based on Machine Learning. The application of the tool system has produced satisfactory outcomes. It is clear from the performance of the three subsystems: (1) the multiple sensors data acquisition tool subsystem, (2) the local web application monitoring subsystem, and (3) the Android phone monitoring subsystem. In addition to the descriptive examination of the tool system's generated data. The system can produce data sets with precision statistical values. The most accurate prediction

model for predicting soil PH as an indicator of soil fertility was derived through a comparison of multiple Machine Learning algorithms. These findings indicate that the tool system has a positive effect on soil PH factor data. Due to the availability of large data, real-time data, and precision predictions, the behavior of soil PH factor indicators may be comprehended. The tool system is then capable of autonomous data monitoring and user-friendly display. Can then operate for an extended period of time. So, it becomes more energy-cost efficient.

The implication for the future is that this monitoring tool system should be added with Nitrogen-Phosphorus-Potassium sensors to measure soil nutrients. Also, the system added edge-analysis to be integrated in monitoring and analyzing soil nutrients. Edge-analysis by adding the concept of Fuzzy Logic with the Mamdani procedure to detect deficiencies or excesses of Nitrogen-Phosphorus-Potassium in the soil. Results of detection of deficiency or excess of soil nutrients. Then it is conveyed to the user (farmer) via message notification the amount of nutrients needed by the soil. Message notifications via social media such as WhatsApp, Telegram or Email. So by adding edge-analysis in the monitoring system will help farmers make real-time and automatic decisions.

ACKNOWLEDGMENT

We would like to thank the Ministry of Education and Culture, Research and Technology's Directorate of Research, Technology, and Community Service, KEMENDIKBUD RISTEK, Indonesia. Because all research activities and the conclusion of this work can be accomplished with the 2022 Beginner Lecturer Research Grant.

REFERENCES

- [1] T. Tambunan, "Recent evidence of the development of micro, small and medium enterprises in Indonesia," *J. Glob. Entrep. Res.*, vol. 9, no. 1, pp. 1–15, 2019, doi: 10.1186/s40497-018-0140-4.
- [2] Asian Development Bank, *Policies to support investment requirements of Indonesia's food and agriculture development during 2020-2045*, no. October 2019. 2020. doi: 10.22617/TCS190447-2.
- [3] E. Calderón-Monge and D. E. Ribeiro-Soriano, "The role of digitalization in business and management: a systematic literature review," *Rev. Manag. Sci.*, pp. 1–43, 2023, doi:10.1007/s11846-023-00647-8.
- [4] E. Endris and A. Kassegn, "The role of micro, small and medium enterprises (MSMEs) to the sustainable development of sub-Saharan Africa and its challenges: a systematic review of evidence from Ethiopia," *J. Innov. Entrep.*, vol. 11, no. 1, 2022, doi: 10.1186/s13731-022-00221-8.
- [5] P. Saha, V. Kumar, S. Kathuria, A. Gehlot, V. Pachouri, and A. S. Duggal, "Precision Agriculture Using Internet of Things and Wireless Sensor Networks," in *2023 International Conference on Disruptive Technologies (ICDT)*, 2023, pp. 519–522. doi:10.1109/ICDT57929.2023.10150678.
- [6] S. H. Awan, S. Ahmad, Y. Khan, N. Safwan, and ..., "A Combo Smart Model of Blockchain with the Internet of Things (IoT) for the Transformation of Agriculture Sector," *Wirel. Pers.*, 2021, doi:10.1007/s11277-021-08820-6.
- [7] F. Akhter, "Design and development of an IoT-enabled portable phosphate detection system in water for smart agriculture," *Sensors Actuators, A Phys.*, vol. 330, 2021, doi: 10.1016/j.sna.2021.112861.
- [8] M. Dhanaraju, P. Chenniappan, K. Ramalingam, S. Pazhanivelan, and R. Kaliaperumal, "Smart Farming: Internet of Things (IoT)-Based Sustainable Agriculture," *Agriculture*, vol. 12, no. 10. 2022. doi:10.3390/agriculture12101745.
- [9] V. R. Pathmudi, N. Khatri, S. Kumar, A. S. H. Abdul-Qawy, and A. K. Vyas, "A systematic review of IoT technologies and their

- constituents for smart and sustainable agriculture applications,” *Sci. African*, vol. 19, p. e01577, 2023, doi: 10.1016/j.sciaf.2023.e01577.
- [10] D. Xue and W. Huang, “Smart Agriculture Wireless Sensor Routing Protocol and Node Location Algorithm Based on Internet of Things Technology,” *IEEE Sens. J.*, vol. 21, no. 22, pp. 24967–24973, 2021, doi: 10.1109/JSEN.2020.3035651.
- [11] A. Degada, H. Thapliyal, and S. P. Mohanty, “Smart Village: An IoT Based Digital Transformation,” *2021 IEEE 7th World Forum Internet Things*, pp. 459–463, 2021, doi: 10.1109/WF-IoT51360.2021.9594980.
- [12] M. E. Karar, F. Alotaibi, A. Al-Rasheed, and O. A. Reyad, “A Pilot Study of Smart Agricultural Irrigation using Unmanned Aerial Vehicles and IoT-Based Cloud System,” *ArXiv*, vol. abs/2101.0, 2021, doi: <https://doi.org/10.1007/s11846-023-00647-8>.
- [13] Q. T. Minh, V. Gla, S. N. Tan, P. N. Huu, and T. Tsuchiya, “Fog Computing Enabled Hydroponic Farming Systems,” *J. Mob. Multimed.*, vol. 18, pp. 981–1008, 2022, doi: 10.13052/jmm1550-4646.1842.
- [14] A. D. Boursianis, “Smart Irrigation System for Precision Agriculture - The AREThOU5A IoT Platform,” *IEEE Sens. J.*, vol. 21, no. 16, pp. 17539–17547, 2021, doi: 10.1109/JSEN.2020.3033526.
- [15] M. Zhu and J. Shang, “Remote Monitoring and Management System of Intelligent Agriculture under the Internet of Things and Deep Learning,” *Wirel. Commun. Mob. Comput.*, vol. 2022, 2022, doi:10.1155/2022/1206677.
- [16] R. K. Singh, R. BERKVENs, and M. WEYn, “AgriFusion: An Architecture for IoT and Emerging Technologies Based on a Precision Agriculture Survey,” *IEEE Access*, vol. 9, pp. 136253–136283, 2021, doi: 10.1109/access.2021.3116814.
- [17] R. Akhter and S. A. Sofi, “Precision agriculture using IoT data analytics and machine learning,” *Journal of King Saud University - Computer and Information Sciences*, 2021, doi:10.1016/j.jksuci.2021.05.013.
- [18] M. Goudarzi, H. Wu, M. S. Palaniswami, and R. Buyya, “An Application Placement Technique for Concurrent IoT Applications in Edge and Fog Computing Environments,” *IEEE Trans. Mob. Comput.*, vol. 20, pp. 1298–1311, 2021, doi: 10.1109/TMC.2020.2967041.
- [19] Z. Han, “Research on Big Data Mining Application of Internet of Things Based on Artificial Intelligence Technology,” in *2022 International Conference on Computing, Robotics and System Sciences (ICRSS)*, 2022, pp. 74–77, doi:10.1109/ICRSS57469.2022.00025.
- [20] S. Garg, P. Pundir, H. Jindal, H. Saini, and S. Garg, “Towards a Multimodal System for Precision Agriculture using IoT and Machine Learning,” *2021 12th International Conference on Computing Communication and Networking Technologies, ICCCNT 2021*, 2021, doi: 10.1109/ICCCNT51525.2021.9579646.
- [21] R. Akhter and S. A. Sofi, “Precision agriculture using IoT data analytics and machine learning,” *Journal of King Saud University - Computer and Information Sciences*, vol. 34, no. 8, pp. 5602–5618, 2022, doi: 10.1016/j.jksuci.2021.05.013.
- [22] S. Suhag, N. Singh, S. Jadaun, and P. Johri, “IoT based Soil Nutrition and Plant Disease Detection System for Smart Agriculture,” in *Proceedings - 2021 IEEE 10th International Conference on Communication Systems and Network Technologies, CSNT 2021*, 2021, pp. 478–483, doi: 10.1109/CSNT51715.2021.9509719.
- [23] I. T. J. Swamidason, S. Pandiyarajan, K. Velswamy, and P. L. Jancy, “Futuristic IoT based Smart Precision Agriculture: Brief Analysis,” *J. Mob. Multimed.*, vol. 18, no. 3, pp. 935–956, 2022, doi:10.13052/jmm1550-4646.18323.
- [24] F. Alrowais, “Hybrid leader based optimization with deep learning driven weed detection on internet of things enabled smart agriculture environment,” *Comput. Electr. Eng.*, vol. 104, 2022, doi:10.1016/j.compeleceng.2022.108411.
- [25] K. Phasinam, T. Kassaruk, and P. P. Shinde, “Application of IoT and Cloud Computing in Automation of Agriculture Irrigation,” *J. Food Qual.*, vol. 2022, 2022, doi: 10.1155/2022/8285969.
- [26] V. Viswanatha, R. V. S. Reddy, and R. Ac, “Implementation of IoT in Agriculture: A Scientific Approach for Smart Irrigation,” *MysuruCon 2022 - 2022 IEEE 2nd Mysore Sub Section International Conference*, 2022, doi: 10.1109/MysuruCon55714.2022.9972734.
- [27] A. Rehman, T. Saba, M. Kashif, and S. M. Fati, “A Revisit of Internet of Things Technologies for Monitoring and Control Strategies in Smart Agriculture,” *Agronomy*, vol. 12, no. 1, 2022, doi:10.3390/agronomy12010127.
- [28] V. K. Quy *et al.*, “IoT-Enabled Smart Agriculture: Architecture, Applications, and Challenges,” *Applied Sciences (Switzerland)*, vol. 12, no. 7, 2022, doi: 10.3390/app12073396.
- [29] H. Yin, Y. Cao, B. Marelli, and X. Zeng, “Soil Sensors and Plant Wearables for Smart and Precision Agriculture,” *Advanced Materials*, vol. 33, no. 20, 2021, doi: 10.1002/adma.202007764.
- [30] A. Sengupta, B. Debnath, A. Das, and D. De, “FarmFox: A Quad-Sensor-Based IoT Box for Precision Agriculture,” *IEEE Consum. Electron. Mag.*, vol. 10, no. 4, pp. 63–68, 2021, doi:10.1109/MCE.2021.3064818.
- [31] H. M. Rai, M. Chauhan, H. Sharma, N. Bhardwaj, and L. Kumar, “AgriBot: Smart Autonomous Agriculture Robot for Multipurpose Farming Application Using IOT,” *Lect. Notes Electr. Eng.*, vol. 875, pp. 491–503, 2022, doi: 10.1007/978-981-19-0284-0_36.
- [32] D. Dey, N. S. Sizan, and M. S. Mia, “GreenFarm: An IoT-Based Sustainable Agriculture with Automated Lighting System,” in *Lecture Notes in Networks and Systems*, 2023, pp. 517–528, doi: 10.1007/978-981-19-3679-1_43.
- [33] K. Kour, D. Gupta, K. Gupta, D. Anand, and D. H. Elkamchouchi, “Monitoring Ambient Parameters in the IoT Precision Agriculture Scenario: An Approach to Sensor Selection and Hydroponic Saffron Cultivation,” *Sensors*, vol. 22, no. 22, 2022, doi: 10.3390/s22228905.
- [34] N. N. Thilakarathne, M. S. A. Bakar, P. E. Abas, and H. Yassin, “Towards making the fields talks: A real-time cloud enabled IoT crop management platform for smart agriculture,” *Front. Plant Sci.*, vol. 13, 2023, doi: 10.3389/fpls.2022.1030168.
- [35] D. Alghazzawi, O. Bamasaq, S. Bhatia, A. Kumar, P. Dadheech, and A. Albeshri, “Congestion Control in Cognitive IoT-Based WSN Network for Smart Agriculture,” *IEEE Access*, vol. 9, pp. 151401–151420, 2021, doi: 10.1109/access.2021.3124791.
- [36] I. M. Kulmány, Á. Bede-Fazekas, A. Beslin, and Z. Giczi, “Calibration of an Arduino-based low-cost capacitive soil moisture sensor for smart agriculture,” *J. Hydrol. Hydromechanics*, vol. 70, no. 3, pp. 330–340, 2022, doi: 10.2478/johh-2022-0014.
- [37] A. P. Atmaja, A. E. Hakim, A. P. A. Wibowo, and L. A. Pratama, “Communication systems of smart agriculture based on wireless sensor networks in IoT,” *J. Robot. Control*, vol. 2, no. 4, pp. 297–301, 2021, doi: 10.18196/jrc.2495.
- [38] K. Ramana, R. Aluvala, M. R. Kumar, G. Nagaraja, A. V. Krishna, and P. Nagendra, “Leaf Disease Classification in Smart Agriculture using Deep Neural Network Architecture and IoT,” *J. Circuits, Syst. Comput.*, 2022, doi: 10.1142/S0218126622400047.
- [39] K. A. Jani and N. K. Chaubey, “A Novel Model for Optimization of Resource Utilization in Smart Agriculture System Using IoT (SMAIoT),” *IEEE Internet Things J.*, vol. 9, no. 13, pp. 11275–11282, 2022, doi: 10.1109/jiot.2021.3128161.
- [40] R. A. Abdelouahid, O. Debauche, and A. Marzak, “Internet of Things : Things : a new Interoperable IoT Platform . Application to a Smart Building,” *Procedia Comput. Sci.*, vol. 191, no. 2019, pp. 511–517, 2021, doi: 10.1016/j.procs.2021.07.066.
- [41] A. Rio and F. Brito e Abreu, “PHP code smells in web apps: Evolution, survival and anomalies,” *J. Syst. Softw.*, vol. 200, p. 111644, 2023, doi:10.1016/j.jss.2023.111644.
- [42] S. Tangwannawit and P. Tangwannawit, “An optimization clustering and classification based on artificial intelligence approach for internet of things in agriculture,” *IAES Int. J. Artif. Intell.*, vol. 11, no. 1, pp. 201–209, 2022, doi: 10.11591/ijai.v11.i1.pp201-209.
- [43] Y. Mekonnen, S. Namuduri, L. Burton, A. Sarwat, and S. Bhansali, “Review - Machine Learning Techniques in Wireless Sensor Network Based Precision Agriculture,” *Journal of the Electrochemical Society*, vol. 167, no. 3, 2020, doi: 10.1149/2.0222003JES.
- [44] W. Zheng, Y. Zhao, H. Xu, Y. Yuan, W. Wang, and L. Gao, “Stretchable Iontronic Pressure Sensor Array With Low Crosstalk and High Sensitivity for Epidermal Monitoring,” *IEEE Electron Device Lett.*, vol. 44, no. 3, pp. 516–519, 2023, doi:10.1109/led.2023.3240764.
- [45] K. Murugan, S. L. Reddy, B. S. Prasad, and P. Ramprasad, “Integration of pH and Temperature Sensor for Biomedical Applications,” *2022 7th Int. Conf. Commun. Electron. Syst.*, pp. 354–361, 2022, doi:10.1109/ices54183.2022.9835719.
- [46] J. Hrisko, “Capacitive Soil Moisture Sensor Theory , Calibration , and Testing,” no. July, 2020, doi: 10.13140/RG.2.2.36214.83522.
- [47] C. Hirsch, E. Bartocci, and R. Grosu, “Capacitive Soil Moisture Sensor Node for IoT in Agriculture and Home,” *2019 IEEE 23rd International Symposium on Consumer Technologies, ISCT 2019*, pp. 97–102, 2019, doi: 10.1109/ISCE.2019.8901012.
- [48] S. Chowdhury, S. Sen, and J. Sreekanth, “Comparative Analysis and Calibration of Low Cost Resistive and Capacitive Soil Moisture Sensor,” *ArXiv*, vol. abs/2210.0, 2022, doi:10.48550/arXiv.2210.03019.

- [49] T. L. Maxwell, L. Augusto, Y. Tian, W. Wanek, and N. Fanin, "Water availability is a stronger driver of soil microbial processing of organic nitrogen than tree species composition," *Eur. J. Soil Sci.*, vol. 74, 2023, doi: 10.1111/ejss.13350.
- [50] H. Pal and S. Tripathi, "A survey on IoT-based smart agriculture to reduce vegetable and fruit waste," *Journal of Physics: Conference Series*, vol. 2273, no. 1, 2022. doi: 10.1088/1742-6596/2273/1/012009.
- [51] Riaman, Sukono, S. Supian, and N. F. Ismail, "Mathematical Modeling for Estimating the Risk of Rice Farmers' Losses Due to Weather Changes," *Comput.*, vol. 10, p. 140, 2022, doi:10.3390/computation10080140.
- [52] M. L. Jat *et al.*, "Chapter Three - Conservation agriculture for regenerating soil health and climate change mitigation in smallholder systems of South Asia," vol. 181, D. L. B. T.-A. in A. Sparks, Ed., Academic Press, 2023, pp. 183–277. doi:10.1016/bs.agron.2023.05.003.
- [53] M. K. Dharani, M. Bharathi, K. Praveena, and K. M. T. Venkata, "Intelligent IoT-based greenhouse monitoring and control system," *i-manager's J. Electron. Eng.*, 2022, doi: 10.26634/jele.12.4.19061.
- [54] J. Park and H. Na, "Changes in Evapotranspiration and Growth of Gold Mound, Japanese Spurge, and Ivy Plants According to Wind Speed," *J. Bio-Environment Control*, vol. 30, no. 1, pp. 72–76, 2021, doi:10.12791/ksbec.2021.30.1.072.
- [55] J. Nithyashri, R. Kumar, S. Balakrishnan, M. A. Kumar, P. Prabu, and S. Nandhini, "Measurement : Sensors IOT based prediction of rainfall forecast in coastal regions using deep reinforcement model," *Meas. Sensors*, vol. 29, no. February, p. 100877, 2023, doi:10.1016/j.measen.2023.100877.
- [56] Sivagami, A. Vaishali, R. Ramakrishnan, and A. Subasini, "Weather Prediction Model using Savitzky-Golay and Kalman Filters," *Procedia Comput. Sci.*, vol. 165, pp. 449–455, 2019, doi:10.1016/j.procs.2020.01.005.
- [57] M. Alom, Y. Ali, T. Islam, A. Hasib, and W. Rahman, "Species classification of brassica napus based on flowers , leaves , and packets using deep neural networks," *J. Agric. Food Res.*, vol. 14, no. November 2022, p. 100658, 2023, doi: 10.1016/j.jafr.2023.100658.
- [58] R. N. Singh, P. Krishnan, C. Bharadwaj, and B. Das, "Improving prediction of chickpea wilt severity using machine learning coupled with model combination techniques under field conditions," *Ecol. Inform.*, vol. 73, pp. 1574–9541, 2023, doi:10.1016/j.ecoinf.2022.101933.
- [59] K. Azizi, S. Ayoubi, and J. A. M. Demattê, "Controlling factors in the variability of soil magnetic measures by machine learning and variable importance analysis," *J. Appl. Geophys.*, vol. 210, p. 104944, 2023, doi: https://doi.org/10.1016/j.jappgeo.2023.104944.
- [60] S. Rodríguez, G. Tatiana, and G. Carlos, "A System for the Monitoring and Predicting of Data in Precision Agriculture in a Rose Greenhouse Based on Wireless Sensor Networks," *Procedia Computer Science*, vol. 121, pp. 306–313, 2017. doi: 10.1016/j.procs.2017.11.042.
- [61] V. Bachuwar, S. A.D, and D. L.P, "Monitoring the soil parameters using IoT and Android based application for smart agriculture," *AIP Conference Proceedings*, vol. 1989, 2018. doi: 10.1063/1.5047679.
- [62] A. Nayyar, "Smart farming: Iot based smart sensors agriculture stick for live temperature and moisture monitoring using arduino, cloud computing & solar technology," *Communication and Computing Systems - Proceedings of the International Conference on Communication and Computing Systems, ICCCS 2016*. pp. 673–680, 2017. doi: 10.1201/9781315364094-121.
- [63] C. Nicolas, B. Naila, and R.-C. Amar, "TinyML Smart Sensor for Energy Saving in Internet of Things Precision Agriculture platform," *International Conference on Ubiquitous and Future Networks, ICUFN*, vol. 2022, pp. 256–259, 2022. doi:10.1109/icufn55119.2022.9829675.
- [64] H. Yin, Y. Cao, B. Marelli, X. Zeng, A. J. Mason, and C. Cao, "Soil Sensors and Plant Wearables for Smart and Precision Agriculture," *Advanced Materials*, vol. 33, no. 20, 2021. doi:10.1002/adma.202007764.