

Development and Working Test of Microcontroller-based Automatic Seedling Tools for Hydroponic Systems

Ernawati Syahrudin Kaseng^{a,*}, Mutmainnah Ashta Syifani^a, Andi Muhammad Akram Mukhlis^a

^a Agricultural Technology Education, Faculty of Engineering, Makassar, Indonesia

Corresponding author: *ernawatisyahrudin71@unm.ac.id

Abstract—This study aims to design a tool that can monitor moisture and light automatically and find out the performance of lettuce seeding tools that can monitor moisture and light automatically. This research is descriptive research using the type of Research and Development (R & D) research with the Waterfall method. The variables controlled are light and moisture using soil moisture sensors and grow light. The automatic seedling tool modification process consists of 3 stages: making mechanical components, electronic comments, and functional checking and product testing. The data obtained from the sensor readings will be displayed on the LCD screen in the control box. The results showed that the seedling tool can monitor moisture when the moisture is below 60%, the pump will be on, and when the moisture is above 60%, the pump will be off, and the light produced with grow light will turn on at 06.00 to 6.00 pm every day. Researchers recommend adding moisture to every shelf, growing lights or LED sensor lights, and fans for further research based on their findings. As a consideration and reference resource addressing the current science on the manufacture and performance test of seedling tools that can monitor moisture and light automatically, incorporating the most recent ideas and information on creating and evaluating seedling equipment with automatic light and moisture monitoring. It is anticipated that this researcher will serve as a seeding industry reference.

Keywords—Seedling tools; moisture; microcontroller.

Manuscript received 8 Jan. 2024; revised 12 Feb. 2024; accepted 17 Mar. 2024. Date of publication 30 Apr. 2024.
IJASEIT is licensed under a Creative Commons Attribution-Share Alike 4.0 International License.



I. INTRODUCTION

Agriculture has existed for a long time; over time, people have developed various ways to grow crops [1], [2]. One of them is a planting technique known as hydroponics [3]–[6]. Hydroponics has been around since the 16th century. Since then, this high-tech farming method has become more popular and known worldwide [7]–[9]. Hydroponics comes from the Greek words: *hydro* meaning water and *Ponos* meaning labor [7], [9]. The literal meaning of hydroponics is waterwork [10]. Hydroponics is known as a method of growing plants without soil (planting, cultivating).

At first, people planted using the hydroponic method with containers filled with water mixed with macro and micro fertilizers. The development of plant cultivation using the aquatic environment continues to develop over time [11], [12]. Along with the shrinking planting area in urban areas, many people cannot plant at will. In addition, hydroponic plant cultivation systems can be done anywhere and there is a lot of support to help grow plants with good yields. Hydroponics is a method of growing crops without using soil

media [13], [14], but by using nutritious mineral solutions or other materials that contain nutrients, such as coconut husk, mineral fiber, sand, broken bricks, and sawdust as a substitute for soil media. Agricultural cultivation technology with a hydroponic system is expected to be an alternative for people who have limited land in plant cultivation [15]–[17]. Hence, it can be used as an innovation for the community in cultivating plants [17]. The cultivation of vegetable crops using the hydroponic method is difficult in the management process. In addition, many things must be considered in the process of growing hydroponic methods, such as nutrient solutions, EC (*Electrical Conductivity*) values, Relative Humidity (RH), water flow, nutrient discharges, gutter slope, planting media, seeding process [5], [18]–[24].

Seed seeding is an essential process in the cultivation stage. The development of plant seeds is influenced by the amount of nutrients obtained through the growing media used. If the seeds are planted at too close a distance, there will likely be competition for nutrients so that the plants cannot grow optimally [25]. The primary purpose of making seeds is to provide good quality seeds in adequate quantities by the planting plan. Seeding vegetable seeds is still manually done

by placing them in a dark place and controlling the planting media so that they continue to moisten until the sprout seeds, then transfer the seeds to the sun until the leaves appear and are ready to be transferred to the enlargement site. This work requires quite a lot of middle to control periodically. The advantage of using seedling tools in seedling is that it is easy to control the moisture of the growing media, the seeds are only in one place, reduce the risk of failure, and get enough light. Seed quality strongly affects crop success [26], [27].

This research measures the performance of lettuce seeding tools. Lettuce (*Lactuca sativa*) belongs to the group of vegetable crops known in the scientific community, farmers, and society [28]. This type of vegetable contains nutrients, especially vitamins and minerals that are complete to meet the nutritional needs of the community. Lettuce can be consumed in fresh form as vegetables that are eaten together with other foodstuffs. Lettuce is not native to Indonesia, but it can grow in Indonesia. This plant tends to be cultivated at high altitudes with an optimum temperature of 15-25 °C and requires moderate light [29]. If lettuce is cultivated in the lowlands, it is recommended to use shade so that the microclimate conditions (temperature, moisture and light intensity) are optimal. The selection of varieties also determines the yield of crop production. Genetic traits under plants and plant adaptation to the environment are determinants of high production, resistant to plant disturbing organisms, and tolerant of certain ecological conditions, so as to increase plant productivity.

Hence, plant water is needed. Plant water needs are defined as the amount of water needed by plants in a period to grow, produce properly and normally, or water needs to meet evapotranspiration in plants [30]. Water needs in plants are inseparable from the growing soil media that is generally used as a planting medium [31]. It plays an important role in providing water for plants, which is indicated by moisture in the soil. Soil moisture is the amount of water that fills the pore space in the soil, either partially or completely [32]–[34]. It is a very dynamic thing caused by the rate of evaporation through the soil surface, transpiration and percolation.

To read the value from the capacitive moisture sensor, the Arduino Uno can be used. The Arduino Uno microcontroller is a microcontroller-based *board* on the ATmega328 [35]. *The board* has 14 digital *input/output* pins (of which 6 pins can be used as PWM *outputs*), 6 analog *inputs*, 16 MHz crystal acidifiers, USB connections, and a power in *jacks* reset button. In order for the microcontroller to be used, the Arduino uno board must be connected to a computer using a USB cable or voltage source. The voltage source can be obtained from an AC to DC adapter or using a battery to run it. The Arduino uno microcontroller is integrated with the Ds18b20 temperature sensor which is a temperature sensor with a linear output voltage. While the RH meter sensor is used to monitor the acidity level.

The Arduino Uno is setup to monitor and control light conditions for plants in real-time [36], [37]. The light that plants need is not always the same in every plant. There are types of plants that require full light and some that require dimness for growth. Sunlight is one of the factors that affect the process of plant growth through its three properties, namely light intensity, light quality (wavelength) and duration of irradiation (day length). The influence of these three

properties of light on plant growth is through the formation of chlorophyll, opening of stomata, formation of anthocyanins (red pigment), changes in leaf and stem temperature, nutrient absorption, cell wall permeability, transpiration and protoplasmic movement.

To measure how seeds respond to light during germination, the ratio of infrared phytochromes to total phytochromes is used [36], [37]. Red phytochromes can inhibit germination while far infrared phytochromes allow germination. Non-dormant seeds will become dormant when the seeds are placed in far red light. When the seeds are placed in dark conditions will slowly change from dormant to non-dormant. Light and dark light conditions give a significantly different response to areca nut seed germination, dark conditions are good for seed germination compared to light conditions.

Light intensity readings might be impacted by the moisture content of the soil requires the use of soil moisture sensor. *Soil* moisture sensor FC-28 is a moisture sensor that can detect moisture in the soil [38]. This sensor is very simple, but it is ideal for monitoring water needs in city parks, even on plants in the yard. This sensor consists of two *probes* that function to pass current through the soil and then read the resistance results to obtain a value of moisture levels in the soil. The amount of water in the soil is very influential on the work of this sensor. The greater the amount of water contained makes it easier for the soil to conduct electricity (small resistance). Conversely, on dry soils it will be very difficult to conduct electricity (large resistance). This sensor is very helpful as a monitor and reminder of moisture levels in plant growing media or soil moisture.

To water the plants, a pump is used that can be connected to the Arduino microcontroller, which controls the operation of the pump. A pump is a device that functions to convert mechanical power from a power source (drive) into kinetic power (speed) [39]. This energy is useful for draining liquids and overcoming obstacles that exist along the flow. In everyday life applications, there are many applications related to pumps. Current pumps have two types of *power supply*, the *first* is AC alternating current power supply and the second is direct current power supply or better known as DC [40].

Another element of supporting plant grow is ultraviolet light. It has a wavelength ranging from 100-380 nm. The energy of sunlight used by plants for photosynthesis turns out to be only 0.5 to 2% of the amount of energy available. The energy that the beam gives depends on the quality (wavelength), intensity (number of rays per 1 cm^2 second), and length of time. Manipulation of sunlight can be used by lamps. Hydroponic cultivation using lamps as a light source can be done in a closed space. Chlorophyll can absorb and utilize light at waves of 700 to 400 nm. Blue light is good for maintaining plant vegetative processes and red light is good for enhancing generative processes. According to [41], *Light Emitting Diode* (LED) can be used to enhance plant growth because it does not emit high temperatures.

As time goes by, the demand for vegetables is increasing directly to a higher economic value. However, this increase is not offset by land area and less use of vacant land. In addition, the cultivation techniques carried out are still simple, and good vegetable cultivation techniques are not paid attention to, so the production of vegetables is still low. Hydroponic vegetable production is needed to meet the needs of

vegetables [4]. The initial stages start from preparing tools and materials, seeding, pest and disease control, and seed transfer.

The seeding process aims to reduce deaths due to plants not being ready for field conditions, whether it protects them from weather or other disturbances. Seeding is an effort to provide good quality seeds in sufficient quantities by the planting plan [42]. Based on information obtained through communication with hydroponic farmers, Problems in the lettuce seeding process in the hydroponic industry, namely Seed seeding, require persistence. In this process, farmers must put the planting media in a container that contains seeds, then cover the top with a container that will occasionally be opened to give water to the planting media.

So, a renewable technology tool is needed that can do automatic seeding that can control the sowing plants, with some application of technological components such as microcontrollers and sensors [43]–[45]. Through this research activity, researchers intend to provide solutions in the form of microcontroller-based automatic seeding tools that are considered to facilitate the hydroponic industry. Microcontroller-based automatic seeding tools with an accuracy above 90% can automatically monitor moisture and light. Thus, the solutions offered can increase the productivity of the hydroponic industry in monitoring and controlling seed sowing.

Based on the background described above and referring to the goals to be achieved, this study's problem formulation is how to design a lettuce seeding device that can monitor moisture and light automatically. The other problem is how the performance of lettuce seeding equipment performs when using a tool that can monitor moisture and light automatically. Therefore, this study aims to design a device that can automatically monitor moisture and light and analyze the performance of lettuce seeding equipment that can do the same.

II. MATERIALS AND METHOD

A. Materials

The tools used in this study were 220V 60-Watt solder, dt-830b digital Avometer, pliers, screwdriver set, ruler, solder tin suction, hand grinder, documentation tools (mobile phones), and stationery. The materials used in this study are clear acrylic thickness 3mm, Arduino uno ATmega 328, DC pump 12V DRAT input capacity 18 mm output 18 mm, 2 relay modules 5V 1 channel, push button R13-50716 mm, I/O switch, LED lamp / Grow light 1: 4 (1 blue and red), LCD 1602 char blue backlight, hole nozzle 0.6 mm, hinge, hose 5/16, power supply 12V 10A, Step down LM2596S DC-DC Adjustable with digital voltmeter, moisture sensor FC-28, RTC DS3231, 30 cm jumper cable (male to male, female to male, and female to female), red and black fiber cable 2x0.75mm, PE hose 6 mm, PCB board 10 X 25 cm, resistor 1000HM1/4W, heat shrink/burn insulation (2mm, 4mm), water, Rockwool and lettuce plant seeds.

B. Methods

The type of research used in this study is the type of *Research and Development* [46]. The research flow chart can be seen in Fig. 1. The procedure for developing

microcontroller-based automated seeding tools for hydroponic systems is outlined as follows:

1) Analysis Stage

The analysis stage collects information that can be used as material to make products. This information is analyzed to determine the materials needed to make the product. The analysis was based on shortcomings from previous research found in seeding tools.

2) Design Stage

The design stage is carried out to facilitate researchers' creation of products. It consists of design criteria, structural design, and functional design. The tool must detect moisture in the growing medium in the design criteria. The moisture sensor can control the moisture in the growing medium during seeding. Acrylic material with a thickness of 3 mm is expected to be strong enough in tool construction. Using type 1 LED lights, 4 (1 blue and 4 red) as light sources.

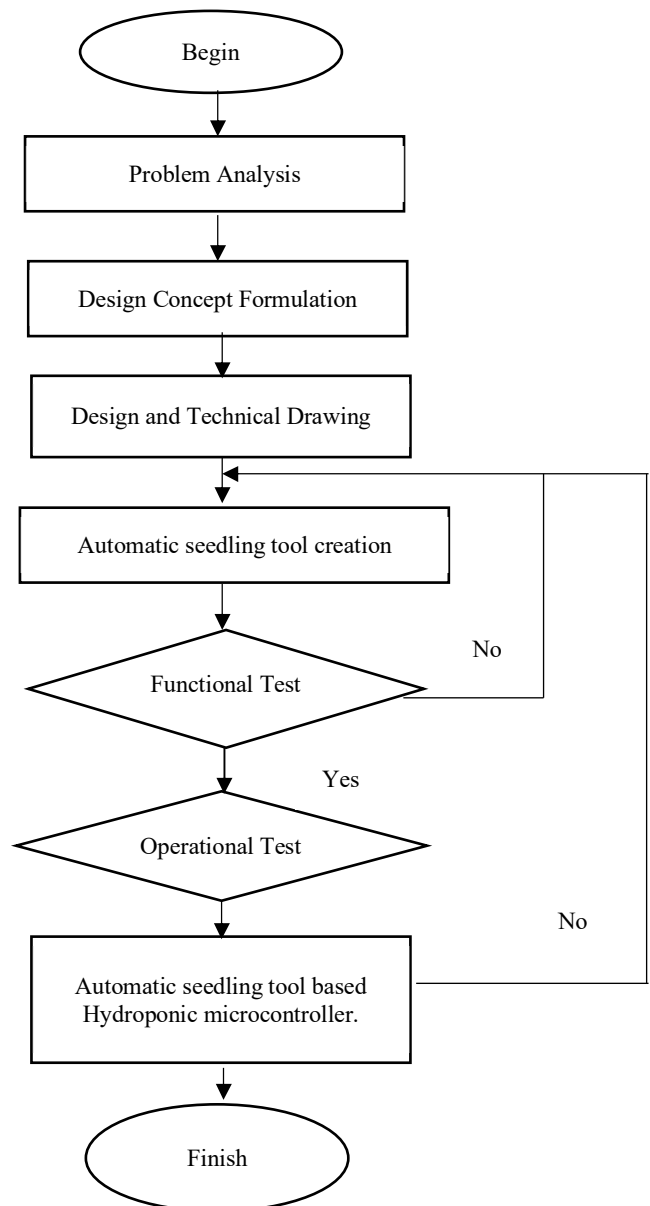

Fig. 1 Research Flow Chart

The Structural design comprises the product design drawings seen in Fig. 2.

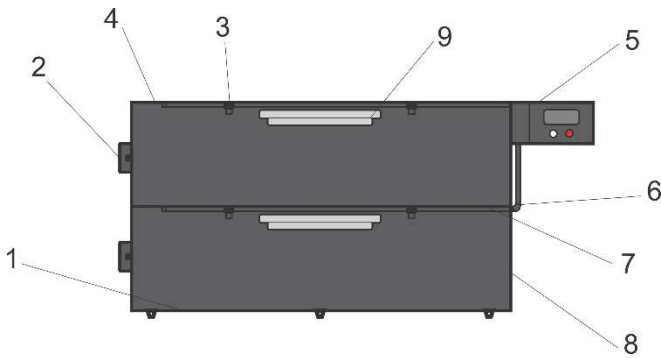

Fig. 2 Structural Design

Notes: 1). Cover; 2) Nozzle Sprayer; 3) Sowing box; 4) Control box; 5) water hose; 6)12V Pump; 7) Water Tub; 8) LED Light/Grow Light.

Based on the structural design in Fig. 2, the researchers describe these components as follows:

1. Cover. This part is made of 3 mm acrylic, is 600 mm long, and is 200 mm high.
2. Nozzle Sprayer. The sprayer nozzle used is the dew sprayer nozzle with a radius of 0.7-0.9 m, a hole size of 0.6 mm, and a working capacity of 1.5-3.0 to spray water onto rock wool.
3. Seed box. The sowing box is made of acrylic with a thickness of 3 ml and dimensions of 600 mm in length, 400 mm in width, and 400 mm in height. The beak box has some space blocked using Acrylic.
4. Control box. The control box used is 200mm x 185 mm x 70mm. Inside the control box, there is a microcontroller.

The microcontroller used is a package with an Arduino uno Atmega 328 microcontroller.

5. Water hose. The interval used is a 6 mm PE interval of black color
6. DC12V pump. The pump used is a DC pump type 12V 5A pump with a capacity of 100 PSI
7. Water bath. The water reservoir is made of 3ml acrylic, measuring 400x150x95 mm and holding 5.7 liters of water.
8. LED/Grow light. The lights used are LED/Grow Light lights in red and blue with a comparison of 1:4 (1 blue and 4 Red)

The functional design describes the function of each component used. The sow box serves as a place for sowing seeds. The control box is a central place for monitoring the seeding process in the seedling box. The pump drains water from the reservoir to the seedling box with a capacity of 5.7 liters. The water reservoir serves to hold water for watering plants. This moisture sensor serves to detect inertia in rock wool. The sensor operates as long as the seedling device is active; the sensor only provides moisture data managed by the system, and then the system gives commands to the relay when the relay on the pump is on, and the relay of the pump is off. LED light/Grow light. LED lights function as a substitute for sunlight.

The control system can be described in the form of a flowchart. A flowchart is a chart of various symbols showing a program's steps or flow. Flowcharts are used to illustrate the working steps of the created system. Flowcharts are used to demonstrate control systems using algorithms and block diagrams. The algorithm and block diagram of the control system can be seen in Fig. 3 and 4.

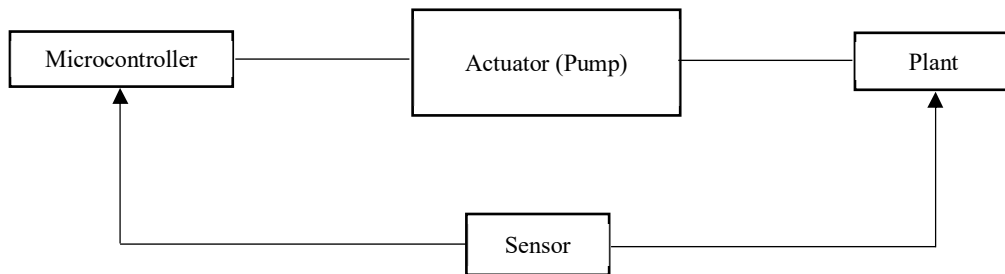

Fig. 3 Software Algorithms

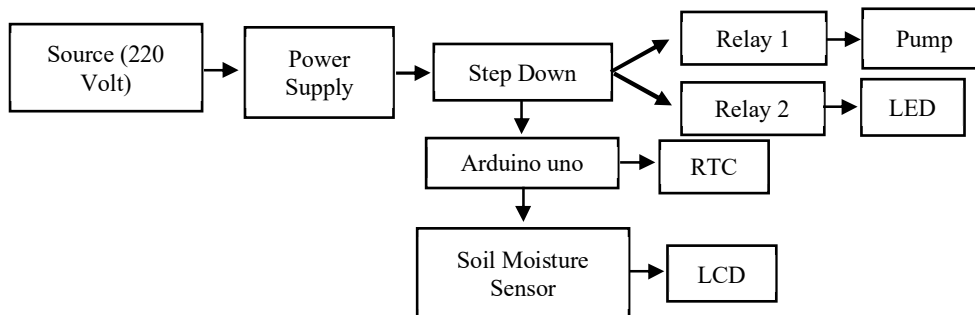

Fig. 4 Block Diagram

In the algorithm drawing and block diagram above, it can be concluded that the working principle of the tool, namely the power source on the tool, is AC with 12V. To do seeding with seeding tools, the components used are push buttons, LED lights/Grow lights, and 12V water pumps. In this

section, there is a nozzle sprayer. The pump will perform composting when the moisture sensor is less than 60%, and the LED/Grow light will turn on automatically. In the seeding process, Arduino Uno is the control center.

3) Implementation Phase

The implementation stage is the stage of realizing the development of the previous product into a new product. The result of this stage is an automatic seedling tool based on a microcontroller that will be tested. The implementation phase includes mechanical component manufacturing and electrical component manufacturing. Mechanical component manufacturing comprises (1) Preparing tools and materials using acrylic and other supporting components; (2) Assembling the main frame in the form of seedling boxes and water troughs according to the design; (3) On the mainframe, hook the acrylic box, pump, and water bath; (4) After all the main components are connected to the frame, connect the water reservoir with the pump with a hose and connect the pump with the nozzles using a hose; (5) Assembling the control box using acrylic placed next to the control box.

While electrical components manufacturing covers (1) Prepare tools and materials in the form of ATmega 328 microcontrollers and other components; (2) Minimum system design to unify circuits into one connection; (3) Install LED lights/Grow lights, hoses and moisture sensors used as seedling beds; (4) Connect the LED/Grow light, moisture sensor and pump to the minimum system present in the control box using a cable; (5) Creation of coding/programs to run each input/output device.

4) Testing phase

Functional testing ensures each component works as expected. Testing is done within one day to test the functionality before deployment. If components are not functioning correctly, the revision stage I is carried out. After it is stated that the element is by its function, it proceeds to the testing stage.

Sensor testing is carried out by testing the error rate of the moisture sensor by comparing the measurement results with the Moisture meter. To determine the accuracy of the sensor, calculations are carried out with the following formula:

$$error = \frac{\text{Difference in sensor readings}}{\text{Original score of sensor}} \times 100\% \quad (1)$$

Sensor error rate testing was carried out three times. If the error is high, a calibration method is carried out on the sensor value. The calibration model is presented in graphic form, with the relationship between the sensor reading value as the X-axis and the reference Moisture meter as the Y-axis. Furthermore, the liner equation model will be used as program code for reading the moisture value on the microcontroller.

LED/Grow light testing is carried out by connecting the cable on the 12V LED/Grow light to the power supply to ensure the 12V LED / Grow light is functioning correctly. To ensure the DC12V pump is functioning properly, the pump's

existing cable is connected to the power supply. Automatic seedling testing includes 1) LED light/Grow light, 2) sprayer spraying, and 3) planting medium moisture. We use a moisture sensor for this tool. Moisture is controlled so that the plants on the resulting seedling can develop properly.

Moisture regulator testing is carried out by observing when the LED / Grow light is off and on. The observation reviews the moisture value produced when the LED / Grow light is off, and the LED/Grow light is on. Testing of grow light using keeping the lights on at 06.00-18.00 WITA and LED/Grow light will be off and 18.00-06.00 WITA. The growing conditions of seedling yield are observed in the number of dead plants, the number of live plants, and the condition of etiolated plants. The plant is said to die if the seed does not experience seed *pecca* or the stem is not visible on Rockwool (growing medium). A plant is said to be alive if the seed undergoes seed *pecca* and a stem appears on Rockwool (growing medium). A plant is said to be etiolated if it undergoes thin, tall, and slim growth (finches).

C. Data Collection Techniques

The data collection techniques used in this study used observation methods and documentation studies. This technique is similar to another study [47] We used a research protocol that included documentation and observation in the hydroponics system. The observation method carried out in this study is non-participant observation when researchers conduct operational tests of the tools created. We also used documentation study methods to collect and analyze written and image documents as well as electronic documents, which aim to assist researchers in collecting data.

D. Data Analysis Technique

The data analysis technique used in this study is quantitative data analysis with descriptive statistics. This study is limited to performance tests, so the data presented is a ratio of data obtained from performance test results. Data obtained from testing automatic seedling tools used in hydroponic seedlings is a reference in this paper.

III. RESULTS AND DISCUSSION

Microcontroller-based automatic seedling tools have been developed based on the planned product image design. From the design of the drawing, each principal component of the tool is made and then assembled into a single tool by the product image design designer. The product manufacturing process consists of 3 stages, including manufacturing main frame components, electrical components, and tool programs, as shown in Fig. 5. The tools would then be used for lettuce seeding. Here are the stages of creating a designed tool.

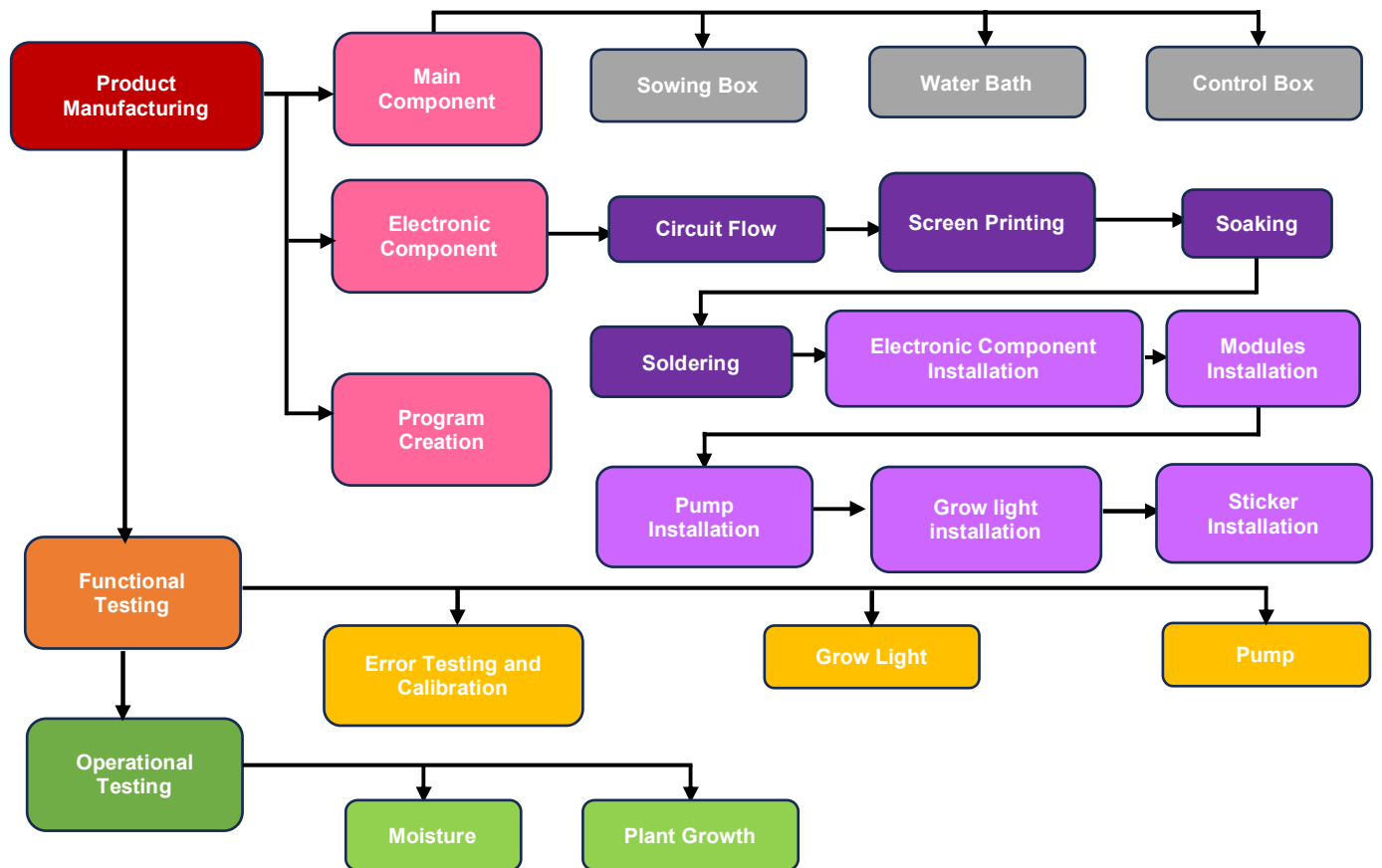

Fig. 5 The development of seedling tools in a hydroponic system

A. Product Manufacturing

1) *Main component*: The main frame component of an automatic seedling tool based on a microcontroller in a hydroponic system consists of a sowing box, water bath, and control box. The seedling box frame is made of acrylic with a thickness of 3 mm, length 600mm x 40mm, as many as 5 sheets as a base, cover, support, and door, acrylic 400mm x 400mm, as many as 2 sheets as left, proper side support and 400mm x 200mm acrylic as much as 2 sheets as a support in the middle of the seedling box room. Furthermore, the acrylic is connected using glue to form a rectangle. Inside the seedling box frame is divided into 4 parts and is bounded by each room using acrylic. The frame and door of the seedling box are connected using acrylic hinges. The seedling frame has 5 holes, including 4 hose line holes and 1 cable hole.

The water bath is made of acrylic, with a thickness of 3 mm, with dimensions of 400mm x 150mm, as many as 2 sheets, and acrylic, size 150mm x 95mm, as many as 2 sheets, and size 400mm x 95mm, as a base. The acrylic is connected using glue so that it forms a rectangle. The water bath has a capacity of 5.7 liters. The control box is made of acrylic with a thickness of 3 mm and a size of 200mm x 185mm. As many as 2 sheets are used as the base and cover of the control box, acrylic size is 185mm x 70mm, and as many as 4 sheets are used as a wall covering the side of the box. Furthermore, the acrylic is connected using glue to form a box. The frame and door of the control box are connected using hinges. The control box has several holes that serve as cable paths. On the door, there is LCD 1602 and a push button.

2) *Electronic components*: The first stage carried out before making the circuit is the design of the circuit path. After designing the path, draw the groove. Drawing grooves is done using Corel Draw. Next, draw the groove in print using receipt paper. Screen printing is done by pasting the receipt paper that has been printed with a circuit flow image on a PCB board. After gluing, it is heated using an iron. In the casting process, the iron attaches the image on the receipt paper to the PCB board. PCB soaking is carried out using a ferric chloride solution. Soak the printed circuit board (PCB) with ferric chloride to remove the copper layer. The copper layer on the PCB board serves as a conductor path. The component installed on the PCB board is then soldered using a tin so that the element is well placed with copper PCB soldering must be done carefully so that the component line does not experience connection errors that can cause shorts on the circuit line.

Installing microcontroller-based automatic seedling equipment electronic components consists of preparing a PCB board with holes and then placing LCD, ITC, relay 5V1 channel, sensor, RTC DS3231, and button components that have been pre-designed. PCBs that have been installed and soldered are then installed modules such as LCD, step down, power supply, relay 5V1 channel, sensor Moisture, RTC DS3231 and connection cables for buttons, so that each component can be integrated each component is well positioned and connected with jumper cables to the Arduino Uno microcontroller. When installing the module, what needs to be considered is the position when connecting one

component line with another so that the positive, negative, and Arduino pins do not occur connection errors.

Pump installation is done by connecting the pump between the relay 5V1 and the power supply 12V10A. Connect the pump, relay 5V1, and power supply 12V10A, then attach the hose from the water bath to the pump with a hose that has been connected to the nozzle in the seedling box. At the time of pump installation, the positive and negative paths need to be considered so that connection errors do not occur, and attention must be paid to the input and output lag lines so that no errors occur. The grow light is installed by connecting the pump between the relay and the power supply. Connect the pump, relay, and power supply, then attach the grow light cable from the seedling box to the control box. When installing grow light, what needs to be considered is the position of the positive and negative paths so that errors do not occur. The grow light test is carried out by connecting the grow light with Arduino Uno, which has been given coding on at 06.00 and off at 18.00. The stickers are installed by opening the glue paper part and then putting it together in a series of seedling boxes and control boxes. When installation, the sticker must be applied thoroughly so that no wind bubbles arise.

3) *Program creation:* Making microcontroller-based automatic seedling tool programs for hydroponic systems. The programming language uses the C program language with the Arduino uno IDE application. This language is object-oriented and will be executed according to the commands that will be executed. Then the program language created is inputted into the microcontroller system in this study. The next step is the microcontroller hydroponic system and program language input is completed. Testing is carried out on each microcontroller component to find out that the circuit path and program language input are functioning properly. System testing of the tools aims to see the performance of the installed tools. The tool will be given a working voltage to see the performance of the automatic seedling tool that has been inserted. Testing is carried out in stages to determine the parameters and indicators of system testing.

B. Functional Testing

1) *Error testing and calibration:* Sensor calibration tests are performed with different water applied in each rockwool to determine the level of accuracy on the sensor. The sensor used for calibration is a soil moisture sensor. Before calibrating the measuring instrument that will be used to ensure the accuracy of the measuring instrument used to calibrate the sensor on the tool made. The results of the first sensor error level test as well as the moisture sensor calibration sample can be seen in Table 1. Based on Table I shows the results of measuring soil moisture sensor data and moisture meters as a test of sensor error levels and soil moisture sensor calibration. At RH conditions 75% has a difference of 0% between the value of the standard measuring instrument and the sensor measuring instrument. Table I shows that the lowest error rate was at 0% moisture, and the highest sensor error rate was 62% moisture, obtaining the highest error rate of 17.3%.

TABLE I
FIRST ERROR RATE TEST RESULTS AND CALIBRATION SAMPLES OF SOIL SLAB
SENSOR AND MOISTURE METER

No	Sensor measuring instruments	Standard measuring instruments	Sensor Error Rate
1	60%	67%	10.4%
2	70%	73%	4.1%
3	75%	75%	0%
4	80%	83%	3.6%
5	54%	51%	5.8%
6	62%	75%	17.3%
7	74%	77%	3.8%
Average			6.42%

Based on the calculation of the sensor error rate from the seven-moisture data obtained, the average sensor error rate is 6.42%. The high level of sensor errors that occur is caused by the uncalibrated sensor used in the tool that has been made. Sensor calibration aims to reduce the value of sensor errors that occur, thereby reducing the difference between moisture sensor and moisture meter readings. Based on the moisture sensor readings and readings using a moisture meter before calibration, they have a relatively different value. Furthermore, the results of the sensor and moisture meter reading data in calibration were obtained using an Excel formula where the reading value of the soil moisture sensor is the y-axis, and the reading value of the moisture meter is the x-axis. Based on these data, the following graph is obtained.

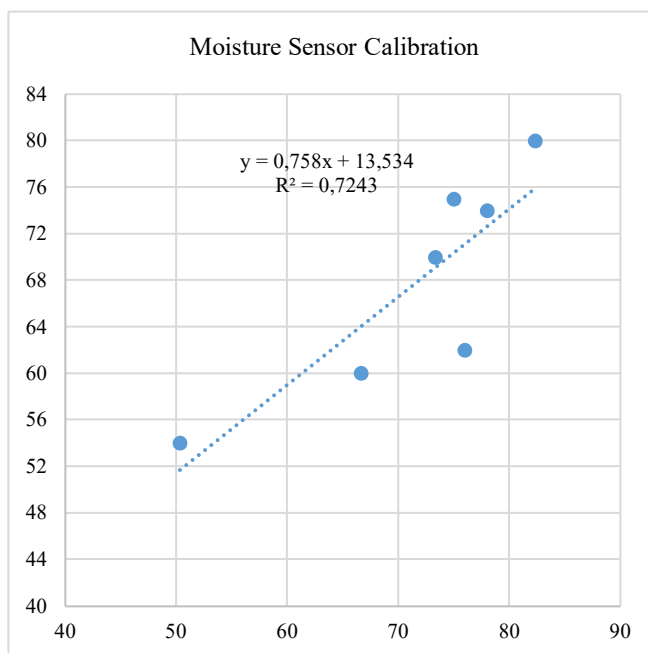

Fig. 6 Soil moisture sensor calibration results

Fig. 6 above shows the results of soil moisture sensor calibration using an excel formula in the form of a linear graph, so that the reading of the moisture meter sensor program uses the equation $y = 0.0758 x 13.534$ to minimize the percentage of sensor error. The moisture meter sensor test focuses on moisture readings to determine the sensor error level after calibration by comparing the readings of the moisture sensor and moisture meter. The test method is carried out 3 times, then the sensor error is calculated. Sensor error rate testing after calibration is carried out again to test

the accuracy of the sensor after calibration. The test results of the moisture error ratio are given in Table II. Table II shows the sensor readings in tests with 3 experiments. In the first test, the sensor error rate was 2.9% and then increased to 4.4% with an RH difference of 3% in the second test. This value has a big difference with the moisture meter reading. The error rate on the third test was 1.5% and the RH difference was 1%. This value has not much difference between the three experiments, so the average sensor error rate is 2.9%. This value is still within normal limits to be used as a benchmark for sensor accuracy.

TABLE II
TEST RESULTS OF THE ERROR RATE OF SOIL MOISTURE SENSOR AND MOISTURE METER

N	Sensor measuring instruments	Standard measuring instruments	Error Rate
1	65%	67%	2.9%
2	65%	68%	4.4%
3	65%	66%	1.5%
Average			2.9%

2) *Grow light*: The grow light test is carried out by connecting the grow light with Arduino Uno which has been given coding on at 06.00 and off at 18.00. Grow light used in 10.5-Watt tools with a grow light length of 1500 mm. after testing for 2 days LED/Grow light on at 06.00 and off at 18.00 operates according to the coding that has been made.

TABLE IV
SENSOR MOISTURE TEST RESULTS ON GROW LIGHT

DD/MM/YY	Grow light	Pump	Hours	Moisture		Error score	Temperature	Environmental moisture
				Tool sensor	Standard tools			
03/07/2023	Off	Off	17.30	71%	65%	9.0%	27.1	71%
04/07/2023	On	Off	06.23	70%	69%	1.4%	30.0	99%
05/07/2023	Off	Off	23.52	70%	69%	1.4%	28.0	99%
	On	Off	06.49	68%	65%	4.65%	33.0	99%
06/07/2023	Off	Off	22.41	69%	67%	2.9%	37.0	73%
	On	Off	07.02	69%	67%	2.9%	31.0	66%
07/07/2023	Off	Off	22.41	66%	65%	1.5%	28.0	86%
	On	Off	06.15	70%	67%	4.4%	37.9	73%

The table shows the readings of the moisture sensor when grow light off and light on, the trial is carried out every morning and evening for 4 days. Tests are carried out to find out if the pump is operating properly when the sensor moisture readings match the system that has been made.

2) *Plant growth*: The results of testing plant growth rates on microcontroller-based automatic seedling tools in hydroponic systems in lettuce seeding can be seen in Table V.

TABLE V
PLANT GROWING CONDITIONS

Plant	Condition			Plant Height
	Dead	Live	Etiolation	
1	-	√	√	20 mm
2	-	√	√	10 mm
3	-	√	√	30 mm
4	-	√	√	40 mm
5	-	√	√	25 mm
6	-	√	√	30 mm
7	-	√	√	17 mm
8	-	√	√	21 mm
9	-	√	√	23 mm
10	-	√	√	20 mm

3) *Pump*: The pump test is carried out by connecting the pump with Arduino Uno where the pump will operate if the moisture level is at <60% and will stop operating at >60%. The results can be seen in the following table.

TABLE III
PUMP TEST

Date	Hours	Moisture Level	
		On	Off
6 Juli 2022	16.04	55%	66%
7 Juli 2022	03.24	59%	62%

C. Operational Testing

Operational testing of microcontroller-based automatic seedling tools in the hydroponic system was tested with tool testing only limited to functional tests, namely moisture control and plant growth.

1) *Moisture*: The results of testing the moisture level of the sensor on a microcontroller-based automatic seedling device when the grow light lights on and grow light turns off in the lettuce seeding process. Moisture control in a program that has been created and calibrated with a standard measuring instrument (moisture meter) hydroponic plant moisture is set at moisture below 60% the pump will turn on and at moisture above 60% the pump will turn off. The test results can be seen in Table IV.

Plant	Condition			Plant Height
	Dead	Live	Etiolation	
11	-	√	√	27 mm
12	-	√	√	19 mm
13	-	√	√	30 mm
14	-	√	√	25 mm
15	-	√	√	19 mm
16	-	√	√	24 mm
17	-	√	√	19 mm
18	-	√	√	20 mm
19	-	√	√	25 mm
20	-	√	√	40 mm
21	-	√	√	30 mm
Average				24 mm

D. Discussion

Based on testing the entire system above, the automatic seedling tool can work according to the characteristics of the research design. This tool works based on a program that has been created and then applied to the Arduino Uno microcontroller, which acts as a brain or command center [48]. Automatic seedling tools in hydroponic systems have soil moisture sensors, LED/Grow lights, nozzles, and pumps. The type of plant used in this study was lettuce (*Lactuca*

sativa L.). In the operational test, several observations were carried out, including moisture, grow light, pump, and seedling yield conditions for 4 days.

1) *Soil moisture sensor testing*: Based on the readings of soil moisture sensors and moisture meters as calibration samples in Table I, the reading values of soil moisture sensors and moisture meter analyzers have a high sensor error rate. The high rate of sensor errors that occur is caused by the uncalibrated sensor used in the tool that has been made. After calibrating the soil moisture sensor reading, the sensor value is obtained. Soil moisture sensor calibration aims to determine the correctness of the conversion of the reading value of the soil moisture sensor. Calibration is carried out regularly to maintain accuracy on the sensor [49]. The results of *moisture* meter and moisture sensor reading data are connected by linear equations with the help of Microsoft Excel application. The read value of the moisture sensor is the x axis and the moisture read value as the y axis. Based on the readings of the moisture sensor and moisture meter, a liner graph is obtained as shown in Figure 6, so that the linear equation formula is $y=0.758x+13.534$ applied to the sensor program. Based on the results of taking error rate data after calibration of the moisture sensor, the error rate reading in Table II is low moisture after calibration on the sensor, which is an average error rate of 2.9%. The smaller the sensor error rate, the difference between sensor readings and standard measuring instruments will be smaller. The smaller the tolerance value of the sensor, the greater the percentage value of accuracy it has [50].

2) *Pump*: Based on the readings of the on and off pumps in Table III, data was obtained that the pump was on 2 times, namely the first pump on at a moisture level of 55% and off at 66%, both pumps on at a moisture level of 59% and off at 62%. On 55% moisture level data, the pump *on* experienced a delay. Pump delay occurs because the slow relay gives commands to the pump so that the moisture reading on the LCD is slow [51].

3) *Operational Testing*: Based on seedling yield growth data in Table IV, the highest moisture value of 71% was obtained and the lowest value was obtained as 66%. The highest moisture value occurs in the afternoon due to the beginning of seeding while the lowest value occurs on the third night the rockwool moisture in the seedling box has a moisture below 60% so that the pump on and pump *off* above 60% moisture. The moisture of rockwool is affected by the temperature level present in the tool.

Moisture control is one activity that must be carried out in the process of seeding hydroponic plants, both in open and closed systems. This control must be carried out periodically. The moisture in the device is maintained, inversely proportional to the temperature / temperature. The higher the temperature, the lower the moisture value and vice versa. The influence of soil moisture on plants is almost the same as temperature because plants really need water [52]. If soil moisture conditions are not suitable, it will adversely affect the growth, production, and quality of fruits. This is closely related as a basic material to be used in the process of photosynthesis which is a plant physiological process for the formation of carbohydrates. To meet water needs and

maintain soil moisture can be done through the watering process [15].

Based on the results of tests that have been carried out, the automatic seedling tool is equipped with grow light (LED lights / *Grow light*) as a substitute for sunlight. The grow light used in the seedling tool is automatically connected to the RTC. RTC serves as a timer and date. Grow light has been set by coding LED / Grow light on 06.00 and LED / Grow light off 18.00. In the seeding process for 4 days the grow light on the tool is lit according to the regulated coding.

Grow light on the tool has several colors light. The blue and red light produces the purple color. Red light and blue light have different effects on plants. Not all colors of light can be absorbed by plants. The color of light absorbed by plants is red and blue light, where red and blue light is good for plant growth, because chlorophyll absorbs red and blue light so photosynthesis can run optimally. The implementation of technology with the addition of LED lighting/*Grow light* with an aeroponic cultivation system on lettuce plants can increase the growth and yield of lettuce plants [53].

Based on the results of growth on lettuce plants for 4 days in Table V obtained plants tested as many as 21 live *rockwool*, having two leaves, small and tall stems. In Table V, the highest stem height value was obtained by 4 cm and the lowest value was obtained by 1.7 cm. small and tall stems are caused by the lack of light obtained. The growth of the playing process is affected by treatment. Another factor that can determine the success of hydroponics is plant care. To ensure the circulation of water and nutrients goes well, treatment must be carried out. The results of automatic seedling device sealing on lettuce seeds experience etiolation due to the lack of light obtained during the seeding process. The light greatly affects plant growth. LED lamps/*Grow light* can emit light colors that can accelerate the process of photosynthesis [54]. Blue color for the vegetative phase and red color for the generative phase.

E. Product Revisions

The development of microcontroller-based automatic seedling tools in hydroponic systems works well, the tool is able to detect the moisture level in *rockwool* well, but the tool still needs to be made some improvements such as naming the moisture sensor material on each shelf, grow light and fans on the tool so that plants do not lack light and can grow well.

IV. CONCLUSION

Microcontroller-based automatic seedling tools are able to monitor moisture and LED / *grow light* in the seeding process consisting of two stages. The first stage, mechanical components include the manufacture of seedling boxes and control boxes. The second stage, the control system component includes the creation of circuits, installation of components and input of program languages in the control system.

Lettuce seeding equipment is able to monitor moisture when the moisture is below 60% then the pump will be on and when the moisture is above 60% the pump will be off, and the light produced with LED / *Grow light* will turn on at 06.00 to 18.00 pm every day. Sorting using an automatic seedling

device on lettuce seeds is etiolated due to the lack of light obtained during the seeding process.

Based on research conducted, researchers suggest adding moisture on each shelf, LED sensor lights / grow lights and fans in future studies. As a consideration and reference material regarding the latest science on the manufacture and performance test of seedling tools that are able to monitor moisture and light automatically. Adding the latest insights and knowledge about making and testing the performance of seedling tools that are able to monitor moisture and light automatically. This researcher is expected to be an industry reference in seeding.

REFERENCES

- [1] T. Yang, K. H. M. Siddique, and K. Liu, "Cropping systems in agriculture and their impact on soil health-A review," *Glob. Ecol. Conserv.*, vol. 23, p. e01118, 2020.
- [2] Z. Tian, J. Wang, J. Li, and B. Han, "Designing future crops: challenges and strategies for sustainable agriculture," *Plant J.*, vol. 105, no. 5, pp. 1165–1178, 2021.
- [3] M. Ruffi-Salis, M. J. Calvo, A. Petit-Boix, G. Villalba, and X. Gabarrell, "Exploring nutrient recovery from hydroponics in urban agriculture: An environmental assessment," *Resour. Conserv. Recycl.*, vol. 155, p. 104683, 2020.
- [4] Y. S. Goh, Y. C. Hum, Y. L. Lee, K. W. Lai, W.-S. Yap, and Y. K. Tee, "A meta-analysis: Food production and vegetable crop yields of hydroponics," *Sci. Hortic. (Amsterdam)*, vol. 321, p. 112339, 2023.
- [5] J. E. Son, H. J. Kim, and T. I. Ahn, "Hydroponic systems," in *Plant factory*, Elsevier, 2020, pp. 273–283.
- [6] G. Niu and J. Masabni, "Hydroponics," in *Plant Factory Basics, Applications and Advances*, Elsevier, 2022, pp. 153–166.
- [7] H. R. El-Ramady *et al.*, "Plant nutrition: from liquid medium to micro-farm," *Sustain. Agric. Rev. 14 Agroecol. Glob. Chang.*, pp. 449–508, 2014.
- [8] D. J. Singh and J. Davidson, *Introduction to Hydroponics-Growing Your Plants Without Any Soil*. Mendon Cottage Books, 2016.
- [9] J. B. Jones Jr, *Complete guide for growing plants hydroponically*. CRC Press, 2014.
- [10] G. Niu and J. Masabni, "Hydroponics," in *Plant Factory Basics, Applications and Advances*, Elsevier, 2022, pp. 153–166.
- [11] C. E. Boyd *et al.*, "Achieving sustainable aquaculture: Historical and current perspectives and future needs and challenges," *J. World Aquac. Soc.*, vol. 51, no. 3, pp. 578–633, 2020.
- [12] P. Edwards, "Aquaculture environment interactions: past, present and likely future trends," *Aquaculture*, vol. 447, pp. 2–14, 2015.
- [13] M. S. Gumisiriza, J. M. L. Kabirizi, M. Mugerwa, P. A. Ndadkemi, and E. R. Mbega, "Can soilless farming feed urban East Africa? An assessment of the benefits and challenges of hydroponics in Uganda and Tanzania," *Environ. Challenges*, vol. 6, p. 100413, 2022.
- [14] P. Kumar, B. Sampath, S. Kumar, B. H. Babu, and N. Ahalya, "Hydroponics, Aeroponics, and Aquaponics Technologies in Modern Agricultural Cultivation," in *Trends, Paradigms, and Advances in Mechatronics Engineering*, IGI Global, 2023, pp. 223–241.
- [15] M. Majid, J. N. Khan, Q. M. A. Shah, K. Z. Masoodi, B. Afroza, and S. Parvaze, "Evaluation of hydroponic systems for the cultivation of Lettuce (*Lactuca sativa* L., var. Longifolia) and comparison with protected soil-based cultivation," *Agric. Water Manag.*, vol. 245, p. 106572, 2021.
- [16] I. A. Lakhari, J. Gao, T. N. Syed, F. A. Chandio, and N. A. Buttar, "Modern plant cultivation technologies in agriculture under controlled environment: A review on aeroponics," *J. plant Interact.*, vol. 13, no. 1, pp. 338–352, 2018.
- [17] S. T. Magwaza, L. S. Magwaza, A. O. Odindo, and A. Mditshwa, "Hydroponic technology as decentralised system for domestic wastewater treatment and vegetable production in urban agriculture: A review," *Sci. Total Environ.*, vol. 698, p. 134154, 2020.
- [18] S. H. Van Delden, M. J. Nazarieljou, and L. F. M. Marcelis, "Nutrient solutions for *Arabidopsis thaliana*: a study on nutrient solution composition in hydroponics systems," *Plant Methods*, vol. 16, pp. 1–14, 2020.
- [19] N. Sadek, N. Kamal, and D. Shehata, "Internet of Things based smart automated indoor hydroponics and aeroponics greenhouse in Egypt," *Ain Shams Eng. J.*, vol. 15, no. 2, p. 102341, Feb. 2024, doi:10.1016/j.asej.2023.102341.
- [20] A. Endut, A. Jusoh, N. Ali, W. B. W. Nik, and A. Hassan, "A study on the optimal hydraulic loading rate and plant ratios in recirculation aquaponic system," *Bioresour. Technol.*, vol. 101, no. 5, pp. 1511–1517, 2010.
- [21] A. Endut, A. Jusoh, N. Ali, W. N. S. Wan Nik, and A. Hassan, "Effect of flow rate on water quality parameters and plant growth of water spinach (*Ipomoea aquatica*) in an aquaponic recirculating system," *Desalin. water Treat.*, vol. 5, no. 1–3, pp. 19–28, 2009.
- [22] A. Venezia, G. Colla, C. Di Cesare, M. Stipic, and D. Massa, "The effect of different fertigation strategies on salinity and nutrient dynamics of cherry tomato grown in a gutter subirrigation system," *Agric. Water Manag.*, vol. 262, p. 107408, 2022.
- [23] B. Siregar, S. Efendi, H. Pranoto, R. Ginting, U. Andayani, and F. Fahmi, "Remote monitoring system for hydroponic planting media," in *2017 International Conference on ICT For Smart Society (ICISS)*, IEEE, 2017, pp. 1–6.
- [24] N. J. Langenfeld and B. Bugbee, "Germination and seedling establishment for hydroponics: The benefit of slant boards," *PLoS One*, vol. 17, no. 10, p. e0275710, 2022.
- [25] R. W. F. Cameron, "Plants and the Environment: Amenity Horticulture," in *Encyclopedia of Applied Plant Sciences*, B. B. T.-E. of A. P. S. Thomas, Ed., Oxford: Elsevier, 2003, pp. 735–741. doi:10.1016/B0-12-227050-9/00221-0.
- [26] A. Schmidt, A. Kirmer, K. Kiehl, and S. Tischew, "Seed mixture strongly affects species-richness and quality of perennial flower strips on fertile soil," *Basic Appl. Ecol.*, vol. 42, pp. 62–72, 2020.
- [27] R. E. Gough, *Seed quality: basic mechanisms and agricultural implications*. CRC Press, 2020.
- [28] V. Matamoros *et al.*, "Occurrence of antibiotics in Lettuce (*Lactuca sativa* L.) and Radish (*Raphanus sativus* L.) following organic soil fertilisation under plot-scale conditions: Crop and human health implications," *J. Hazard. Mater.*, vol. 436, p. 129044, 2022.
- [29] W. G. Owen and R. G. Lopez, "End-of-production Supplemental Lighting with Red and Blue Light-emitting Diodes (LEDs) Influences Red Pigmentation of Four Lettuce Varieties," *HortScience*, vol. 50, no. 5, pp. 676–684, May 2015, doi: 10.21273/HORTSCI.50.5.676.
- [30] H. S. Grewal, B. Maheshwari, and S. E. Parks, "Water and nutrient use efficiency of a low-cost hydroponic greenhouse for a cucumber crop: An Australian case study," *Agric. Water Manag.*, vol. 98, no. 5, pp. 841–846, 2011.
- [31] R. Wallach, "Physical characteristics of soilless media," in *Soilless Culture*, Elsevier, 2019, pp. 33–112.
- [32] C. J. W. van Verseveld and J. Gebert, "Effect of compaction and soil moisture on the effective permeability of sands for use in methane oxidation systems," *Waste Manag.*, vol. 107, pp. 44–53, 2020.
- [33] M. Y. Fattah, Q. G. Majeed, and H. H. Joni, "Comparison between methods of soil saturation on determination of the soil water characteristic curve of cohesive soils," *Arab. J. Geosci.*, vol. 14, no. 2, p. 101, 2021.
- [34] O. T. Faloye, A. E. Ajayi, A. Zink, H. Fleige, J. Dörmer, and R. Horn, "Effective stress and pore water dynamics in unsaturated soils: Influence of soil compaction history and soil properties," *Soil Tillage Res.*, vol. 211, p. 104997, 2021.
- [35] L. J. Bradley and N. G. Wright, "Optimising SD saving events to maximise battery lifetime for Arduino™/Atmega328P data loggers," *IEEE Access*, vol. 8, pp. 214832–214841, 2020.
- [36] A. Kumar, V. Singh, S. Kumar, S. P. Jaiswal, and V. S. Bhadoria, "IoT enabled system to monitor and control greenhouse," *Mater. Today Proc.*, vol. 49, pp. 3137–3141, 2022.
- [37] A. Arunachalam and H. Andreasson, "RaspberryPi-Arduino (RPA) powered smart mirrored and reconfigurable IoT facility for plant science research," *Internet Technol. Lett.*, vol. 5, no. 1, p. e272, 2022.
- [38] P. Bhadani and V. Vashisht, "Soil moisture, temperature and humidity measurement using arduino," in *2019 9th International Conference on Cloud Computing, Data Science & Engineering (Confluence)*, IEEE, 2019, pp. 567–571.
- [39] J. Yang, B. Liu, T. Zhang, J. Hong, and H. Zhang, "Multi-parameter controlled mechatronics-electro-hydraulic power coupling electric vehicle based on active energy regulation," *Energy*, vol. 263, p. 125877, 2023.
- [40] B. Sreewirote, A. Noppakant, and C. Pothisarn, "Increasing efficiency of an electricity production system from solar energy with a method of reducing solar panel temperature," in *2017 International Conference on Applied System Innovation (ICASI)*, IEEE, May 2017, pp. 1308–1311. doi: 10.1109/ICASI.2017.7988141.
- [41] R. C. Morrow, "LED Lighting in Horticulture," *HortScience*, vol. 43, no. 7, pp. 1947–1950, Dec. 2008, doi: 10.21273/HORTSCI.43.7.1947.

- [42] M. F. McDonald and L. O. Copeland, *Seed production: principles and practices*. Springer Science & Business Media, 2012.
- [43] K. Ramesh, K. T. Prajwal, C. Roopini, M. G. MH, and V. S. Gupta, "Design and development of an agri-bot for automatic seeding and watering applications," in *2020 2nd International Conference on Innovative Mechanisms for Industry Applications (ICIMIA)*, IEEE, 2020, pp. 686–691.
- [44] Y. N. Kumar *et al.*, "Automated Seed Sowing Agrirobot," in *2019 IEEE 1st International Conference on Energy, Systems and Information Processing (ICESIP)*, IEEE, 2019, pp. 1–5.
- [45] J. Anto Sheeba, D. Shyam, D. Sivamani, A. Sangari, K. Jayashree, and A. Nazar Ali, "Automated Ploughing Seeding with Water Management System," *Intell. Soft Comput. Syst. Green Energy*, pp. 199–210, 2023.
- [46] R. L. Ison, P. T. Maiteny, and S. Carr, "Systems methodologies for sustainable natural resources research and development," *Agric. Syst.*, vol. 55, no. 2, pp. 257–272, 1997.
- [47] S. J. Conn *et al.*, "Protocol: optimising hydroponic growth systems for nutritional and physiological analysis of *Arabidopsis thaliana* and other plants," *Plant Methods*, vol. 9, no. 1, pp. 1–11, 2013.
- [48] Y.-M. Wu *et al.*, "IoT-interfaced solid-contact ion-selective electrodes for cyber-monitoring of element-specific nutrient information in hydroponics," *Comput. Electron. Agric.*, vol. 214, p. 108266, 2023.
- [49] B. Li *et al.*, "Accuracy calibration and evaluation of capacitance-based soil moisture sensors for a variety of soil properties," *Agric. Water Manag.*, vol. 273, p. 107913, 2022.
- [50] F. A. Purnomo, N. M. Yoeseph, and G. W. Abisatya, "Landslide early warning system based on arduino with soil movement and humidity sensors," in *Journal of Physics: Conference Series*, IOP Publishing, 2019, p. 12034.
- [51] A. I. L. Maldonado, J. M. M. Reyes, H. F. Breceda, H. R. Fuentes, J. A. V. Contreras, and U. L. Maldonado, "Automation and robotics used in hydroponic system," *Urban Hortic. Futur.*, 2019.
- [52] H. Lambers, R. S. Oliveira, H. Lambers, and R. S. Oliveira, "Plant water relations," *Plant Physiol. Ecol.*, pp. 187–263, 2019.
- [53] E. Bogstie, "Vertical Farming: A Viable Strategy for Sustainable Agriculture." Thompson Rivers University, 2021.
- [54] X. Yang, H. Xu, L. Shao, T. Li, Y. Wang, and R. Wang, "Response of photosynthetic capacity of tomato leaves to different LED light wavelength," *Environ. Exp. Bot.*, vol. 150, pp. 161–171, 2018.