

Food Safety and the Implementation of Quality System in Food

Noveria Sjafrina[#] and Alvi Yani^{*}

[#]Jakarta Assessment Institute for Agricultural Technology

^{*}Lampung Assessment Institute for Agricultural Technology
Jl Z.A. Pagar Alam No,1 A. Raja Basa. Bandar Lampung
Email : alvi_yani64@yahoo.com

Abstract— One of the goals the development of the food sector in Indonesia is food secured the release of which is characterized by the type of food that are harmful to health. In some way of avoiding the kind of food that is harmful to health, strengthen institutional food sector, and increase the number of food industry comply with regulations. Implementation of Good Handling Practice (GHP) and Good Manufacturing Practice (GMP) and Hazard Analysis Critical Control Point (HACCP) are a responsibility and awareness of manufacturers and distributors. Some of the food safety regulations have been issued by the government of Indonesia such as Law. 18 on Food in 2012 to provide protection to consumers and food producers will be healthy, safe and lawful. Development of quality systems and food safety and implementation quality system in the food industry are a shared responsibility between government, industry includes producers of raw materials, food industry and distributors, and consumers. The involITLE.

Keywords— Food Safety; Quality Sitem.

I. INTRODUCTION

Food safety is shared responsibility. Governments establish food safety policies and they put in place and manage a system of controls that collectively aim to assure that national food safety goals are met and achieved . National food safety regulations and standards are a fundamental part of the food control system. The modern conception of food control places direct responsibility for food ensuring the safety of food for all operators in the food chain. They must be able to demonstrate to regulate authorities that their operations are in line with national guidelines and codes of practice and that their products a line with the national standards. Consumers also play a role in functioning of national control systems beyond the actual safe handling of food that they purchase or otherwise obtain their choices and concerns influence decisions of government and the food industry.

II. SAFE FOOD

Safety food is the guarantee that the food doesn't produce the risk to the consumer if those were prepared and consumed as per what those used for^[1]. Safety food basically divided into 2 purposes , which discover safe for the body and soul. The safe food for the soul related to the halal determined by the religion and government, and safe

food for the body is related to the food which is free of the biology and microorganism risk which cause the pollution of physic and the chemical .

According to the food safety government regulations No 18. 2012 were aimed to the efforts and the conditions which are required to prevent the possibility of the chemical and biological pollution of the food stuff which harm the health of human beings and contradicting to the religion, society cultural so those will be safe to be consumed.

As the efforts of the implementation of the government regulation above, the government has arranged policies to manage the food storage, providing the food kinds, ensuring the nutrition of the food include the sanitation and the food additional advertisement. The government has also supported related the food safety distribution should discover quality standard as per the food safety government regulation.

Food safety standards may be classified in various types such : (a) numerical standards defining characteristic required for the products such as the contaminant limits or maximum residue limits , (b) Standards process which define how the food should be produced with verifiable performance objectives which may create numerical; (c) standard process the define the requirements of the management system such the standard documentation requirement^[2].

III. MAJOR FACTORS THAT INFLUENT THE FOOD SAFETY STANDARDS

The safe food should not contain biology and microbiological risk include physic and chemical risks microbiological risk define such parasite (protozoa and worms) virus and phatogen bacteria which grow and develop them self on the foodstuff which cause the toxic and infection to the human beings . Basically the pollution of the microbe could be discovered on the junk food or street food available around, catering food, and most favorite ones are the meats, chicken ,fishes and also the traditional foodstuff. The lab test in 8 province level conservation and research discovered 23,6%o of the foodstuff samples are positive contain *Escheria coli* bacteria, which are used for sanitation indicator of the foodstuff. The distribution of the foodstuff which do not comply to standard could be found at many places. From the numbers of yodium salt tested , around 63,30 % - 48,73% of the sample do not comply the standard of KIO₃.^[3]

Chemical hazards are generally caused by the presence of chemicals that can cause intoxication occurs. Poisoning-causing chemicals such as heavy metals (lead/Pb and mercury / Hg). Pesticides, heavy metals, hormones, antibiotics and other drugs used in food production activities are examples of chemical contamination are commonly found in foodstuff, especially vegetables, fruits and some animal food products.

The development of the chemical used in agriculture, in addition to their positive effects and beneficial only, create the potential health hazards caused by the residue of the pesticide food products. The possible negative effects of the residues of the pesticides and other chemical agent feed the stimulate efforts to reduce the use of chemicals in agriculture. Good Agriculture Practice (GAP) in use of the chemicals may be an effective tool in realizing the aim mentioned above^[4].

Physical hazards consist of pieces of wood, stone, metal, hair and nails are probably came from contaminated raw materials, equipment has been worn, or also from food processing workers. Although physical danger does not always lead to disease or health problems, but this danger can be a carrier or carrier pathogenic bacteria and can certainly interfere with the aesthetic value of food that will be consumed.

Other materials are also dangerous to health are coloring, preservatives and other additives of the type that are not used for food. The use of additives unsuitable are: (1) hazardous colour (rhodamine B, methanyl yellow and amaranth) are found mainly on the product syrup, lemonade, crackers, bread, order / jellies, cakes moist, snack food (fried bananas, tofu, fried chicken and *cendol*), (2) specific to dietary artificial sweeteners (cyclamate and saccharin) are used for snack foods, (3) Formalin to preserve tofu and noodles soaked, and (4) Borax for making crackers, meatballs, *empek-empek* and rice cake^[4].

IV. SAFETY FOOD DAN QUALITY SYSTEM

Safety food and quality system is related to the managing, coaching and monitoring toward production process and foodstuff distribution up to the foods are ready to consume,

started by producing process, packing till the distribution and received also consumed by the customer.

Quality system is one prevention effort in producing the safety food concerning to the quality and should be done since the production process to adapt and develop according to the advance science and technology^[5].

Food safety and quality assurance system carried out by producers, consumers and government. Manufacturer is the party most responsible for food safety and food quality for manufacturers who produce food. The main factor that guarantees food security need to be considered by the manufacturer, the choice of raw materials to be used in the production process. Raw materials to be used must be in accordance with the specifications of the material in question as it will determine the safety and quality of the final product. In addition to the selection of raw materials, manufacturers must ensure that during the production process to avoid the possibility of entry of contamination, well contamination, physical, chemical and microbiological, as well as at the time of packaging and labeling of products. Manufacturers must ensure the raw materials and final products are stored separately in a secure warehouse, even the manufacturers need to make the application a good way of food production.

CPMB is a guide that explains how to produce food so that the resulting product is a product that is safe, high quality and suitable for consumption in order to meet quality and safety standards set for food products. Internationally recognized in the application of Good Agricultural Practice (GAP), Good Manufacturing Practice (GMP), Good Handling Practice (GHP) and Hazard Analysis Critical Control Point (HACCP).

GAP is implemented according to the Codex Alimentarius Commission (CAC), the national authorized safe usage of pesticides under actual conditions necessary for effective and reliable pest control. It encompasses a range of levels of pesticide applications up to the highest authorized use, applied in a manner that leaves the smallest residue amount practicable. The experience of developed countries shows that pesticide, when used according to good agricultural practice (GAP), do not harm the human health. GAP includes recommended safe uses of pesticides, taking into account public and occupational health, and environmental safety considerations^[4].

Good Manufacturing Practice is the minimization of risks of contamination in the entire process of food production. Among potential risks, microbiological and chemical contamination should be mentioned. Production facilities should be designed to prevent contamination^[4].

HACCP is an internationally recognized food safety assurance system that concentrates prevention strategies on knows hazards, it focuses on process control, and the steps within that, rather than structure and layout of premises. HACCP establishes procedures whereby these hazards can be reduced or eliminated and requires documentation and verification of these control procedures^[6].

TABLE I
IMPACT OF SAFETY AND QUALITY DEVIATION FOOD
PRODUCTION TOWARD THE GOVERNMENT, PRODUCER OF
FOOD AND SMALL INDUSTRY PRODUCTIO

1) QUALITY DEVIATION AND FOOD SAFETY		
GOVERNMENT	PRODUCER (INDUSTRY)	CONSUMER
<ul style="list-style-type: none"> Investigation of the case Investigation fee analyse Lost of productivity Export delivery order is getting low Security social fee jobless 	<ul style="list-style-type: none"> Cancelling of product order Bankrupt Profitless Investigation of the case cause Lost of the marketing customer Pessimistic in gaining the consumer (domestic and international) Insurance administration Legality fee Rehabilitation fee Consumer demands 	<ul style="list-style-type: none"> Medication and rehabilitation fee Lost of income and productivity Sickness to the death Weasting time Reporting fee

Source: www.bappenas.go.id

V. QUALITY DEVIATION AND PROBLEM SAFETY FOOD

Four major issues of national food quality and safety that affect the food trade both domestically and globally according to Fardiaz [7] are :

First, food products that do not meet the quality requirements of food security, namely: (1) The use of food additives is prohibited or exceeds the limit in food products, (2) Found hazardous chemical contamination (pesticides, heavy metals, drugs farm) on various food products, (3) a high microbial contaminants and pathogenic microbe contamination in various food products, (4) labeling and advertising of food products that are not eligible; (5) Still circulation of expired food products, including imported products, (6) Forgery in food products; (7) How the circulation and distribution of food products that are not eligible, and (8) Quality and safety of food products can not compete in the International market.

Secondly, there are still many cases of food poisoning have been reported and most have not identified the cause.

Third, there is still a lack of knowledge, skill, and responsibility of food producers (producers of raw materials, processors and distributors) about food quality and safety, which is marked by the discovery of the means and distribution of food products that do not meet the requirements (GAP, GHP and GMP), especially in small industrial / household.

And fourth, the low consumer concerns about food quality and safety due to limited knowledge and purchasing power is low, so they still buy food products with quality and safety levels are low.

The deviation of the quality and and safety food production has very critical point toward the government, small industry production and consumer mentioned on the Table 1.

VI. IMPLEMENTASI OF SAFETY FOOD AND QUALITY SYSTEM

Implementing of the national security quality system had been analysed which identify the strength, weekness, opportunity and the risk that we face. The result of identification has determined the policies and rules to a range the strategy, programme and all activities to ensure quality and safety food trading of domestic and international by approaching HACCP according to ISO 9000 (QMS) to produce the consistent qualified products and ISO 1400 (EMS) to ensure the products that comply to the green environment (Figure1). Figure 3 is explaining quality system development and national safety food system concerning to the quality system implementation to every chain of food production process GAP/GFP (Good Agriculture/Farming Practice), GHP (Good Handling Practice) GMP (Good Manufacturing Practice) GD (Good Distribution Practice) GRP (Good Retailing Process) and GCP (Good Catering Practice).

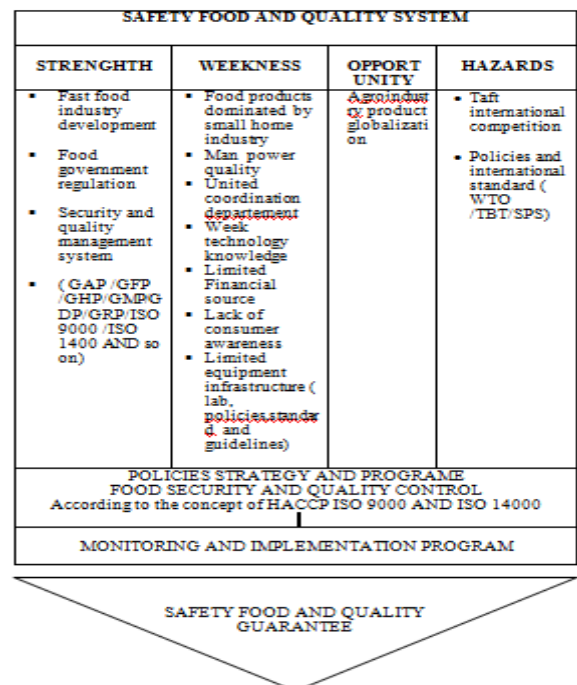

Source: www.bappenas.go.id

Figure 1. Analyze of strength, weekness, opportunity and hazards to the implementation in quality system and safety food

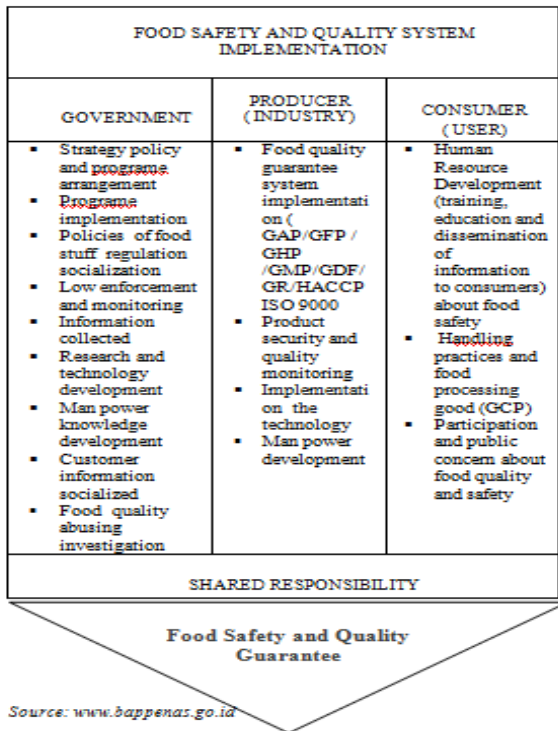

Figure 2. Relation among government responsibility , products industry and consumer in implementing safety food system

VII. SAFETY FOOD SECURITY AND QUALITY SYSTEM POLICY

National policy of the food security guarantee had been arranged in sector mobility involving all related department in coaching and monitoring national foodstuff quality system are:

1. Improving food quality and security through research, and department regulations policies development.
2. Improving quality nutrition in developing society nutrition status.
3. Giving promise and guarantee that foodstuff industry basic and consumable ones are free of chemical biology and toxic contamination , do not against religion followed by the societies.
4. Implementing united safety food and quality guarantee system since preproduction, according to the national standard.
5. Improving self regulatory control towards food producer, consumer, distributor also monitoring quality foodstuff quality guarantee.
6. Blocking the export and import food trading which do not comply to international standard.
7. Certifying qualified foodstuff product which comply to Indonesian national standard (SNI) for the producer ,exporter are able to implement foodstuff quality management system.
8. Keeping the high quality standard in every aspect of united productions, monitoring and controlling and foodstuff quality and security system.
9. Socialize the quality program and national safety food.

10. Developing man power coaching and quality control trough intensive training.

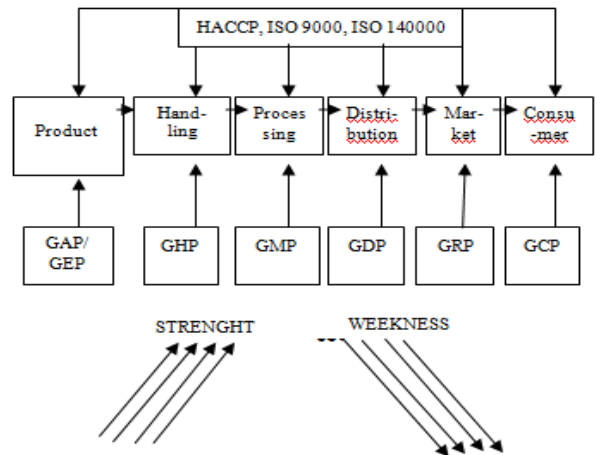

Figure 3. National safety food and quality system

VIII. CONCLUSIONS

Safety food is defined as consumable quality system implementation according to the government regulation and policies standard in ensuring the foodstuff are free of chemicals .biology and microorganism risk also determined as halal as per the religion. Some effort implemented by the government involved foodstuff storage, providing food kinds, ensuring food nutrition includes sanitation and food stuff advertisement. Chemicals role development in agriculture cause potential toxicated contamination towards human being because of the residue of pesticides applied to the food production process. Safety food quality system is created and aimed to ensure and monitor the foodstuff are delivered as per the advance science and international standard since the first food production process, distribution and consumed by the human beings. Safety food and quality abusive should be prevented and vanished for example unauthorized food amenities usage, contain risky pollutant pesticides ,heavy metal and farming chemical which are unacceptable and un consumable in foodstuff production. So the implementation of national security and quality system aimed to identified the strength, weekness, opportunities and risk of food production. National policy of the food security guarantee had been arranged in sectoral mobility involving all related department in coaching and monitoring national foodstuff quality to maintain and protect the consumer gain and consume the safe and qualified foodstuff.

REFERENCES

- [1]. WHO. 1998 *Food Safety Programmes in The South East Asia Region, Overview and Perspective*. WHO Regional Office South East Asia, New Delhi, India.
- [2]. Clarke, R. 2010. *Session of Codex Alimentarius Commision*. FAO. www.fao.org/food/food safety quality
- [3]. Cahyono, B. 1997. *Safety Foodstuff Department Of The National Foodstuff Ministry Office*. www.bappenas.go. id,2006
- [4]. Laszity and Halasz,A. 2013. *Food Chain Management, Food Quality and Standards*,Vol 1 www.eolss.net [Jan, 4 – 2013].

- [5]. Anonymous. 2013. *Repository*. ipb.ac.id. [Jan, 4 – 2013]
- [6]. Egan, MB. 2007. *Review of food safety and food hygiene training studies in commercial sector*. Food Control 18 , page 1180 – 1190.
- [7]. Fardiaz, S. 1996. *Food Control Strategy*, WHO National Consultant Report. Directorate General of Drug and Food Control, Ministry of Health. Jakarta.