

## Design, Testing, and Evaluation of Mobile Corn Mill for Village-Level Operation in the Philippines

Michael A. Gragasin<sup>#</sup>, Irwin V. Salapare<sup>#</sup>, Jayvee P. Illustrisimo<sup>#</sup>, and Romualdo C. Martinez<sup>#</sup>

<sup>#</sup> Agricultural Mechanization Division, Philippine Center for Postharvest Development and Mechanization (PHilMech), Department of Agriculture, CLSU Compound, Science City of Muñoz, Nueva Ecija, 3120, Philippines  
E-mail: kitgragasin@yahoo.com

**Abstract**— The efficiency and availability of corn mills operating in the Philippines play a vital role in achieving food self-sufficiency in the entire country. Majority of operational corn mills are situated along the highway where the three-phase electrical line is available. The current design of operational corn mills still utilizes emery stone for its degermination process, two-steel rollers for its milling process and oscillating sifter that all require huge amount of power. The purpose of this research was to develop a technically viable and financially feasible new type of mobile corn mill that can be used in the countryside particularly in the remote areas. The developed corn mill system is comprised by the degerminator, rotary mill, rotary grader and equipped with a pre-cleaner (destoner and winnower), two elevators and a suction blower and powered by 60 HP, 4-cylinder diesel engine. Performance test results revealed that the developed mobile corn mill has an input capacity of 940 - 1,100 kg/h with product recovery of 66-71 % and degerminator efficiency of 82-88 %. Cost of milling is estimated at Php 0.86 per kg output. The estimated cost of the developed corn mill is Php 850,000 per unit (US\$1=Php50). Farmer cooperatives can use the developed corn mill technology and local entrepreneurs that will engage in custom-milling business, and the processing of corn for food and animal feeds.

**Keywords**— *Zea mays*; corn mill; agricultural machinery; corn processing

### I. INTRODUCTION

One of the major agricultural machinery that has been neglected in the Philippines is the corn mill. The Department of Agriculture estimates a total capacity deficit of corn mill in the Philippines at 4,500 units of 400 kg/h capacity [1]. Likewise, the design of the corn mill machines currently operating in the country is technically inefficient, a more than 50 years old technology that uses emery stone for its degerminator mechanism, two-steel rollers for its milling mechanism, and oscillating sifter for its grading mechanism that all require huge power requirement [2].

Corn is highly nutritious both for human and animal food [3], and a corn mill machine is used in the processing of corn kernels to produce white and yellow corn grits [4]. A kernel of corn is comprised of four main parts, namely: pericarp (also referred to as hull), germ, tip cap, and the endosperm, the primary source in the production of corn grits [3, 5]. Corn grits are milled corn kernels where the tip cap, pericarp, and germ have been removed and with a particle size of not less than 0.86 [6]. Corn grits is a perfect substitute for rice in the Philippines. It is estimated that about 15 % of the country's population has utilized corn as their staple food [8]. Corn grits are also being used as the main ingredient in the production of animal feeds for poultry and livestock [1].

There were initial efforts on the part of the local manufacturers to satisfy the milling requirement in the country with the fabrication of village-type corn mills of different designs. Based on the report of Agricultural Machinery Testing and Evaluation Center (AMTEC) in 2011, however, these newly developed and commercially available village-type corn mills are technically inefficient with very high operating cost per kg output [9]. The results of the performance tests of AMTEC revealed that these corn mills failed to pass the technical specification set by the Philippine Agricultural Engineering Standard (PAES) regarding minimum Product Recovery of 64 % and Degerminator Efficiency of 80 %.

Such technical inefficiency of existing corn mills has been passed on to the farmers. The considerable corn mill deficit in the countryside and the prevalence of antiquated design, which are characterized by the poor performance and high cost of operation of the corn mill, have resulted to pervasive wrong rental practice and the collection of high milling fee being carried out by corn mill operators. The rental cost of corn mill is based on the total weight of corn being milled by the farmers regardless of what happened to the product after milling. This is contrary to the scheme implemented by the rice milling industry where the milling fee is based on the output of the rice mill.

Most of the Filipinos eating corn are living in the remote villages with no available corn mills. As such, they need to transport their corn product to and from the nearest villages with operational corn mill machine to have their corn process.

The purpose of this research was to develop a technically viable and financially feasible mobile corn mill.

## II. MATERIAL AND METHOD

### A. Design of the mobile corn mill

The primary design of the mobile corn mill was based on the principle of the dry-milling process [10, 11] with the omission of tempering of corn kernels before passing through the degermination process.

The technical features of the corn mill were designed based on the conditions and requirements in the key corn producing areas of the country. The design of the different components of the corn mill were conceptualized by the research team particularly the major components of the corn mill such as the degerminator, milling, rotary sifter, pre-cleaning system and conveying mechanisms. The parts and components of the corn mill were all drawn through AutoCAD software featuring the detailed parts of the corn mill in three-dimensional perspective.

### B. Fabrication of Prototype Unit

The fabrication of the prototype unit was partnered with a local private manufacturer that shouldered the cost of labor and materials. The research team closely worked with the partner local manufacturer during the fabrication of the prototype unit to ensure that the engineering design that was prepared and provided by the research team were strictly followed.

### C. Laboratory Testing and Evaluation

Corn grain sample was subjected to physical analysis before the laboratory testing of the machine to determine the initial physical condition of the corn grains.

Laboratory testing regarding the performance of the new machine and/or for each component was conducted following the Method of Test for Corn Mill as prescribed by PAES 211:2000 [12]. The parameters used in establishing the performance of the corn mill are as follows:

$$\begin{aligned} \text{Input Capacity (kg/h)} \\ &= \frac{\text{Weight of corn kernel input (kg)}}{\text{Total loading time (h)}} \end{aligned} \quad (1)$$

$$\begin{aligned} \text{Output Capacity (kg/h)} \\ &= \frac{\text{Weight of main product (kg)}}{\text{Output time (h)}} \end{aligned} \quad (2)$$

$$\begin{aligned} \text{Milling Capacity (kg/h)} \\ &= \frac{\text{Weight of corn kernel input (kg)}}{\text{Total operating time (h)}} \end{aligned} \quad (3)$$

$$\begin{aligned} \text{Main Product Recovery (\%)} \\ &= \frac{\text{Weight of main product (kg)}}{\text{Weight of input (kg)}} \times 100 \end{aligned} \quad (4)$$

$$\begin{aligned} \text{Main By-product Recovery (\%)} \\ &= \frac{\text{Weight of by-product (kg)}}{\text{Weight of input (kg)}} \times 100 \end{aligned} \quad (5)$$

$$\begin{aligned} \text{Electrical Energy Consumption (kWh)} \\ &= \text{Power consumed (kW)} \times \text{Time Operation (h)} \end{aligned} \quad (6)$$

For each laboratory trial, a total of three replicates were conducted using 100 kg of corn samples for each test run, and three samples weighing 100 grams each were collected from the outlets of the different components of the mobile corn mill (degerminator, rotary mill, rotary grader outlets, cyclone) for laboratory analysis.

### D. Field Testing

Once the desired performance of the machine was achieved during laboratory trial, the prototype unit was subjected to field trials at the Tillers Multi-Purpose Cooperative (TMPC), Moncada, Tarlac, the Philippines which is currently engaged in the processing of corn grits with the average total volume of transaction of 120,000 kg per month. It currently uses five (5) different corn mill machines for the cracking, polishing, sorting, grinding, cleaning of corn grits.

The purpose of the field trial was to evaluate the stability of the technical performance of the corn mill and to determine the weak parts of the prototype unit during continuous milling operation of at least two and a half hours, the time prescribed by PAES 211:2000 [12]. Continuous milling of two and a half hours requires 30 bags of 50 kilograms of corn samples or a total of 90 bags of 50 kilograms for a three-replicate test trial alone. The samples needed during field trials were all provided by TMPC as the project cooperator. Likewise, the easiness of operating the portable corn mill by the machine operators was observed. Feedbacks and comments were gathered to further improve the operation and safety features of the developed corn mill technology.

Necessary parameters in the evaluation of the corn mill during field trials were as follows: output capacity (kg/h), milling capacity (kg/h), leading product recovery (%), fuel consumption, labor requirements (person) and degerminator efficiency (%). The test was also conducted following the Method of Test for Corn Mill as prescribed by PAES 211:2000 [12].

### E. Modification and Improvement of the Prototype Unit

The performance of each component of the corn mill and the whole machine were fully observed. Several modifications were undertaken during laboratory and field trials until the target technical performance of the corn mill. The input capacity of 1,000 kg/h, degerminator efficiency of at least 80 % and product recovery of at least 64 % have been achieved. Likewise, modifications on the original design were undertaken to improve the easiness of operation and operator's safety.

### F. Experimental Design and Statistical Analysis

The performance of the developed corn mill machine, i.e., Input Capacity (kg/h), Milling Capacity (kg/h), Main Product Recovery (%), Degerminator Efficiency (%), Percent Flour (%) and Percent Bran (%) were compared according to different set of technical parameters during test trials.

The data gathered were consolidated and analyzed using Analysis of Variance (ANOVA). Statistical analysis was performed using Statgraphics Plus, a statistic package

software that performs and explains basic and advance statistical functions.

### G. Financial Analysis

The financial feasibility of the corn mill was determined using the Internal Rate of Return (IRR), a vital tool in making an investment decision [13]. The IRR is obtained by equating the present value of investment costs (cash outflows), and the present value of net incomes (cash inflows). This can be shown by the following equality:

$$I_0 + \frac{I_1}{(1+r)^1} + \frac{I_2}{(1+r)^2} + \dots + \frac{I_m}{(1+r)^m} = \frac{B_1}{(1+r)^1} + \frac{B_2}{(1+r)^2} + \dots + \frac{B_m}{(1+r)^m}$$

$$\sum_{n=0}^m \frac{I_n}{(1+r)^n} = \sum_{n=1}^m \frac{B_n}{(1+r)^n} \quad (7)$$

where;  $I_0$  is the initial investment costs in the year 0 (the first year during which the project is constructed) and  $I_1 \sim I_m$  are the additional investment costs for maintenance and operating costs during the entire project life period from year 1 (the second year) to year  $m$ .  $B_1 \sim B_m$  is the annual net incomes for the entire operation period (the entire project life period) from year 1 (the second year) to year  $m$ . By solving the above equality, the value of  $r$  or commonly known as the Internal Rate of Return (IRR) was obtained [13].

## III. RESULTS AND DISCUSSION

### A. Basic Design Consideration

The corn mill was designed to move from one place to another to serve various corn villages. To address the waiting time of the farmers during milling, therefore, the target capacity of the corn mill should be 800-1,000 kg/h. Given such technical requirements, the corn mill was powered by 4DR6, 60-hp diesel automobile engine with two-fold function: to drive the vehicle from one place to another and to supply the power requirement of the corn mill that was mounted to the vehicle. Fig. 1 shows the CAD drawing design of the mobile corn mill highlighting its major components.

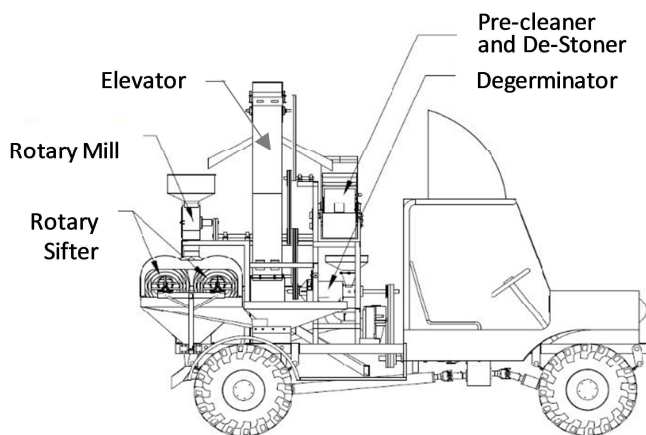

Fig. 1 CAD drawing of the design of the mobile corn mill

In the design and development, the following basic technical parameters were fully considered: (1) Utilization of the power take-off (PTO) of the 4DR6, 60-hp diesel automobile engine for the power requirement of the corn mill; (2) Utilization of pneumatic tire system of the vehicle that can absorb the unevenness of off-road terrain and poor road conditions in the remote areas during transport; (3) Incorporation of readily available body and electrical parts of automobile in the local market such as doors, electrical, ignition system, lighting and signalling system, floor components and parts, switches, powertrain and chassis; (4) Incorporation of two elevators for the separate continuous loading of corn kernels and degermed kernel during milling operation; and, (5) Design and development of a pre-cleaner and de-stoner to remove corn cobs and other light impurities and stones from corn kernels, respectively.

The basic design of the degerminator, the rotary blade mill and the rotary sifter of this corn mill were all based on the primary design of the Compact Corn Mill initially developed by Gragasin, et al., 2015 [2,4]. A bigger degerminator was designed using a carbon steel hexagonal dented screen huller and counter flow steel auger for its rubbing and abrasive mechanisms, and the huller is directly connected to a suction blower to simultaneously separate the hull, germ and tip cap from the endosperm [14]. The milling mechanism of the corn mill used 76 pieces of T-shape rotating blades with a hole at the center and sharpened at both sides to chop de-germinated corn kernels and blown into small particles as they impact to the front wall casing of the rotary mill assembly. The sifter of the corn mill was designed using two units of the four-layer rotating cylindrical screen to sort corn grits sizes of greater than #10, #10, #12, #14-18 and the corn flour.

The Philippine Agricultural Engineering Standard - Corn Mill Specification defines the size of corn grits, as follows [6]:

Corn Grits #10 as milled corn kernels with a particle size between 1.8 mm to 2.0 mm;

Corn Grits #12 as milled corn kernels with a particle size between 1.5 mm to 1.7 mm;

Corn Grits #14 as milled corn kernels with a particle size between 1.2 mm to 1.4 mm;

Corn Grits #16 as milled corn kernels with a particle size between 1.10 mm to 1.19 mm; and,

Corn Grits #18 as milled corn kernels with a particle size between 0.86 mm to 1.09 mm.

Majority of the Filipino corn farmers in the countryside are drying their produce in the highway which usually causes accumulation of tiny stones in the corn kernels. The presence of tiny stones could damage the screen of the degerminator and the rotary mill. Likewise, the presence of corn cobs could cause clogging which eventually damages the degerminator assembly. To address these problems, a pre-cleaner was specifically designed for the mobile corn mill. The pre-cleaner primarily comprises two components, namely: a winnower and de-stoner. The purpose of the winnower is to remove corn cobs and other light impurities while the de-stoner removes stones from the corn kernels. A pressure-type de-stoner is designed for the corn mill that consists of a reciprocating perforated sieve deck and a blower for the production of pressurized air so that stones,

which are not lifted by the air, remain on the deck and are carried backward to the higher end of the sieve [15]. The pressurized air coming from the destoner is recycled for the winnower.

In conveying corn kernels and degermed kernels to the pre-cleaner and the rotary mill, respectively, bucket elevator was incorporated into the design. Bucket-type is efficient in conveying grains and derivatives vertically in continuous flow using large number of buckets that are mounted at regular intervals as an endless string on a high tensile strength modern belts [3]. The first elevator conveys raw and clean corn kernels to the pre-cleaner while the second elevator handles the continuous flow and loading of degermed corn kernels and corn grits bigger than grits #10 to the rotary mill.

### B. Process Flow of the Corn Mill System

The process flow of the corn mill is illustrated in Fig. 2. Corn kernels are loaded to the loading hopper where a feeding control device can regulate the input capacity of the corn mill. It is then conveyed by the first elevator to the pre-cleaner and de-stoner for the removal of corn cobs and other impurities and stones from the corn kernels, respectively. Clean corn kernels then passed through the dented hexagonal screen huller through the aid of the feeding auger. The dented hexagonal screen huller tears the tip cap and germ and peels the hull layer of the corn kernel. The combination of rubbing and grinding actions simultaneously removes the by-products (bran, germ and tip cap from the endosperm). The by-products are then separated from the endosperm through the aid of a suction blower attached to the degerminator. A discharge gate is installed at the tail-end of the dented hexagonal screen huller to regulate the degree of degerming corn kernels.

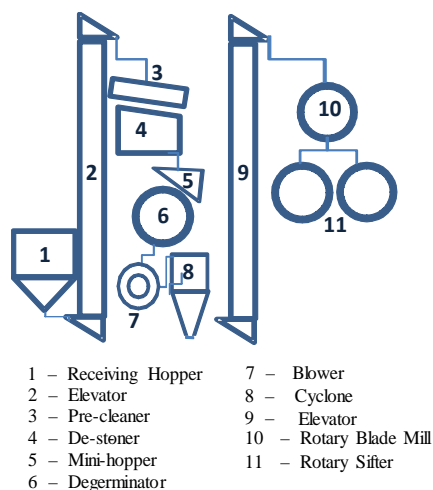

Fig. 2 Process flow of the Corn Mill

From the degerminator, degermed kernels are then conveyed to the rotary blade mill through the second elevator. The main function of the rotary blade mill is to break the initial size of degermed kernels into small pieces to produce corn grits. A control feeding device controls the flow of product to the swing-type rotating blades. The rotating blades cut degermed kernels into small pieces of corn grits while the rest are further blown into smaller particles as they impact to the front wall casing of the rotary

mill. At the bottom surface of the casing is a slotted hole perforated screen, wherein the slot width determines the major size composition of the corn grits.

Corn grits of different sizes then fall to the rotary sifter to sort corn grits of different sizes including the corn flour. It was observed that the rotating sifters also completed the dehulling process when the corn grits are in contact with the rotating screens.

### C. Product Recovery of the Corn Mill

The size of the corn grits is a function of hammer blade speed, hammer blade design, the screen design, and the hole size of the screen [16]. Results of test trial (Table I) revealed that the screen with a slot width of 8 mm has the highest recovery of corn grits #6-8 among all treatments at 71.6 % but has the lowest recovery of corn flour at 3.5 %. On the other hand, the 3 mm screen slot width has the highest milling recovery of corn grits sizes #10, #12, and #14-18 with 13.4 %, 6.3 %, and 8.4 %, respectively. As evident, there is an inverse relationship between the size of the slot width of the screen of the rotary blade mill and the degree of flour produce, that is, as the slot width of the screen increases, the lesser the corn flour produce [2].

TABLE I  
THE COMPOSITION OF CORN GRITS AND CORN FLOUR AFTER MILLING USING DIFFERENT SCREEN SLOT WIDTH

Parameters	8mm	6mm	4mm	3mm
Input weight of degermed corn (kg)	100	100	100	100
Corn grits # 6-8 (%)	71.6 <sup>a</sup>	69.6 <sup>a</sup>	61.3 <sup>b</sup>	53.0 <sup>c</sup>
Con grits # 10 (%)	6.2 <sup>e</sup>	8.1 <sup>d</sup>	10.9 <sup>c</sup>	13.4 <sup>b</sup>
Corn grits # 12 (%)	3.0 <sup>e</sup>	3.9 <sup>d</sup>	5.3 <sup>c</sup>	6.3 <sup>b</sup>
Corn grits # 14-18 (%)	3.9 <sup>e</sup>	5.0 <sup>d</sup>	6.7 <sup>c</sup>	8.4 <sup>b</sup>
Corn flour (%)	3.5 <sup>c</sup>	4.3 <sup>c</sup>	6.4 <sup>b</sup>	7.5 <sup>a</sup>
Main Product Recovery	86.6 <sup>a</sup>	84.6 <sup>ab</sup>	84.3 <sup>ab</sup>	81.1 <sup>b</sup>

Note: Means of a column having the same superscript are not significantly different at 5% level

In the production of white corn grits for human consumption, therefore, it is imperative to use a screen with sloth width of 3.0 mm to produce more corn grits #10-18. The PAES recommends that the size of corn grits for human consumption be #10-18 [6]. In the production of degermed corn for animal feeds, it is imperative to use a screen with a slot width of 8.0 mm since the market requires corn grits with sizes of 2.4-3.4 mm (corn grits #6-8) based on information given by the Tillers Multi-Purpose Cooperative, Moncada, Tarlac, Philippines.

While it appears that the corn mill is producing more corn flour during actual operation, the percent of corn flour is only 3.5 % and 7.5 % of the total weight of samples for 8 mm and 3 mm slot-width of the rotary mill screen, respectively. Based on the result of laboratory analysis conducted in this research, the bulk density of corn flour is around 517 kg/m<sup>3</sup> and 496 kg/m<sup>3</sup>. For hybrid white corn and yellow corn samples as compared to the bulk density of corn grits with #14-18 of about 681 kg/m<sup>3</sup> and 695 kg/m<sup>3</sup> for white corn and yellow corn samples, respectively.



#### D. Performance of the Mobile Corn Mill

Laboratory trials were conducted to test the technical performance of the mobile corn mill to yellow corn and white corn samples using both hybrid varieties. For each test trial, three replicates were undertaken using 100 kg of corn samples or a total of 300 kg for each test trial. A total of two kilograms of corn grits/flour samples were gathered from the outlets of corn grits # 6-8, #10, #12, #14-18, and corn flour for laboratory analysis.

The result of laboratory test trials (Table II) revealed that the input capacity of the mobile corn mill of 1,006 kg/h for yellow corn and 1,080 for white corn are not significantly different with each other. Likewise, the degerminator efficiency, product recovery and the percent bran of the mobile corn mill using yellow corn samples are not significantly different with white corn samples. The result of laboratory trials indicate that the technical performance of the mobile corn mill is not adversely affected by the type of hybrid varieties, that is, whether it is white corn or yellow corn hybrid varieties.

TABLE II  
PERFORMANCE OF THE MOBILE CORN MILL USING BOTH WHITE AND YELLOW CORN HYBRID VARIETIES

Parameters	White Corn	Yellow Corn
Input Cap. (kg/h)	1,080.26 <sup>a</sup>	1,005.80 <sup>a</sup>
Milling Cap. (kg/h)	611.63 <sup>a</sup>	611.41 <sup>a</sup>
Degerminator Efficiency (%)	82.92 <sup>a</sup>	82.96 <sup>a</sup>
Product Recovery (%)	66.37 <sup>a</sup>	66.73 <sup>a</sup>
Percent Flour (%)	4.03 <sup>b</sup>	5.67 <sup>a</sup>
Percent Bran (%)	26.73 <sup>a</sup>	25.67 <sup>a</sup>

Note: Means of a column having the same superscript are not significantly different at 5% level.

#### E. Technical Specifications

Based on the results of both laboratory and field trials of the prototype unit (Fig. 3), the developed mobile corn mill has an input capacity of 940-1,100 kg/h with product recovery of 66-71 % and degerminator efficiency of 82-



Fig. 3 The prototype unit of the developed mobile corn mill 88 %.

It features a hexagonal dented screen huller for its degerminator mechanism, rotary T-shape blades for its grinding mechanism, and a four-layer rotating cylindrical

screen for its sifting mechanism. The mobile corn mill is equipped with pre-cleaner and two elevators.

The corn mill is powered by a 4DR6 automotive engine with a total displacement of 2,199 cc and power rating of 60 hp at 4,000 rpm. Average fuel consumption during the series of test trials was 3.83 l/h.

#### F. Financial Viability of the Corn Mill

The financial viability of the mobile corn mill was analyzed using the gathered data during the technical performance testing of the machine in the laboratory and field trials. The total annual operating time used in the estimation was 600 hours (i.e., 5 months, 20 days per month, and 6 hours of operation per day). A lifespan of the corn mill of 10 years and total investment cost of Php 950,000 (1US\$=Php50) for the corn mill and the shed of the corn mill machine.

The results of the estimation as shown in Table III revealed that the total cost of milling is estimated at Php0.88/kg-output. The current milling fee in the market is Php2-3/kg (input basis) or Php3.10-4.70/kg (output basis).

Based on the estimated cost of milling per kilogram output as shown in Table III, the operator of the mobile corn mill (if the technology is used for custom-milling business). It could realize a net income of Php 0.91/kg even at minimal milling fee of Php 2.25/kg-output and an overhead cost of 20 % of the total milling cost per kg output.

Given such scenario, the estimated net present value of the investment on the developed mobile corn mill technology for 10 years is Php4.11 million with an internal rate of return of 79.81 %.

TABLE III  
TOTAL OPERATING COST, COST OF MILLING, AND INTERNAL RATE OF RETURN

Fixed Cost per Year (Php)	132,500
Depreciation Cost	90,000
Repairs and maintenance	42,500
Variable Cost per Year (Php)	203,940
Fuel Cost	68,940
Labor (3 operators)	135,000
Total Operating Cost per Year (Php)	336,440
Cost of milling per kg output (Php/kg)	0.88
Net Income (Php/kg)	1.10
Net Present Value (Php)	4,114,576
Internal Rate of Return (%)	79.81%

Note: 1US\$=Php50

#### IV. CONCLUSION

The developed mobile corn mill is both technically feasible and financially viable. It has an input capacity of 940 - 1,100 kg/h with product recovery of 66-71 % and degerminator efficiency of 82-88 %.

The result of financial analysis indicates that the total cost of milling per kilogram output was Php 0.88 which is lower than the current milling fee of Php3.10-4.70 per kg output. As such, the estimated net present value of investment was

Php4.11 million with an internal rate of return of 79.81 % for 10 years of operation.

The estimated direct fabrication cost of the developed corn mill including the overhead cost is estimated at Php850,000. Such cost is only 28 % of the current market price of corn mill with similar capacity amounting to Php2.95 million.

#### ACKNOWLEDGMENT

The authors would like to thank the Tillers Cooperative, Moncada, Tarlac, Philippines for its full support and cooperation during the conduct of field testing and the ACT Machinery and Metalcraft Corporation as local partner manufacturer in the fabrication of the prototype unit of the developed technology.

#### REFERENCES

- [1] DA-Corn Program. Corn Industry Development Roadmap. Department of Agriculture, Republic of the Philippines, 2014.
- [2] M.A. Gragasin and R.C. Martinez. Development of Corn Mill for Village-Level of Operation, *Asian Journal of Applied Sciences*, 3(6), pp. 896-904, 2015.
- [3] G. Boumans. "Developments in Agricultural Engineering 4: Grain Handling and Storage". New York, USA: Elsevier, 2012.
- [4] M.A. Gragasin and R.C. Martinez. Pilot-Testing of Developed Village-Level Compact Corn Mill in the Philippines. *ARPN Journal of Engineering and Applied Sciences*, 12(1), pp. 83-88, January 2017.
- [5] F.R. Earle, J.J. Curtis and J.E. Hubbard. Composition of the Component Parts of the Corn Kernel, *Cereal Chemistry*, vol. 23, pp.504-511, 1946.
- [6] "Philippine Agricultural Engineering Standard Specification for Corn Mill (PAES 210:2000)", Agricultural Machinery Testing and Evaluation Center, University of the Philippines at Los Banos, Laguna, Philippines, 2001.
- [7] "Selected Statistics on Agriculture (ISSN 2012-0362), Philippine Statistics Authority, Republic of the Philippines, 2015.
- [8] DA-BAFS, "Philippine National Standards for Shelled Corn (PNS/BAFS 10:204)", Bureau of Agriculture and Fisheries and Product Standard, Department of Agriculture, Philippines, 2014.
- [9] "Summary of Evaluation Report on Village-Type Corn Mill", Agricultural Machinery Testing and Evaluation Center (AMTEC), University of the Philippines, 2011.
- [10] O.L. Brekke, E. Griffin Jr. and P. Brooks . Dry-milling of Opaque-2 Corn. *Cereal Chemistry*, 48, pp. 499-511, 1991.
- [11] A.J. Peplinski, R.A. Anderson and F.B. Alaksiewicz. Corn Dry-milling Studies: Shortened Mill Flow and Reduced Temper Time and Moisture. *Cereal Chemistry*, vol. 61(1), pp.60-62, 1984.
- [12] "Philippine Agricultural Engineering Standard Method of Test for Corn (PAES 211:2000)", Agricultural Machinery Testing and Evaluation Center, University of the Philippines at Los Banos, Laguna, Philippines, 2001.
- [13] J.C. Hartman and I.C. Schafrick. The Relevant Internal Rate of Return. *The Engineering Economist*, 49(2), pp. 139-158, 2004.
- [14] M.A. Gragasin and R.C. Martinez. Design and testing of improved village-type dehuller-degerminator for dry-milling process of corn. *International Journal of Engineering and Advance Technology*, 5(1), pp. 121-126, 2015.
- [15] K.R. Bhattacharya and S. Z. Ali. "An Introduction to Rice-Grain Technology. Woodhead Publishing India, 2015.
- [16] K. Koch. "Hammer Mills and Roller Mills". MF-2018 Feed Manufacturing, Department of Grain Science and Industry, Kansas State University, 2002.