

The Identification of Car Combustion Engine Category on Exhaust Emissions Data Pattern Base Using Sum Square Error Method

Andrizal^{#1}, Lifwarda[#], Anton Hidayat[#], Roza Susanti[#], Nadia Alfitri[#], Rivanol Chadry^{*}

[#] Department of Electrical Engineering, Politeknik Negeri Padang, Padang, West Sumatera, Indonesia
E-mail: ¹andrizalpoli@gmail.com

^{*} Department of Mechanical Engineering, Politeknik Negeri Padang, Padang, West Sumatera, Indonesia
E-mail: rivanolchadry@yahoo.com

Abstract— There are two main categories of combustion condition in the car combustion engine chamber, they are complete and incomplete combustion condition. The complete combustion condition is obtained when a balance of fuel, airflow, and ignition in the combustion chamber occurred. It is characterized by the level of elements and compounds contained in the exhaust emissions. The dominant elements and compounds in exhaust emissions of the gasoline-fueled engine are Hydrocarbon (HC), Carbon Monoxide (CO), Carbon Dioxide (CO₂) and Oxygen (O₂). This study aims to establish a system that is capable of identifying the combustion category of automobile engine through exhaust emissions. This emissions data was procured using gas multi-sensor processed by a Fast Fourier Transform (FFT) process and constructed in the form of the data pattern. The identifying process of the combustion category was done by comparing the detected data pattern with a reference data pattern utilizing the Sum Square Error (SSE) method. Trials had been conducted on some gasoline and *Pertalite* cars for carburetor and injection systems. The trials result showed that the system accuracy in identifying the category of complete combustion was 87% and the incomplete combustion category was 77%.

Keywords— exhaust; data pattern; car combustion; combustion category.

I. INTRODUCTION

Car owners always want their car to be in the optimal state. To get into this condition, they will regularly take their car to an auto repair shop for some services, one of which is combustion engine category tune-up. Combustion engine tune-up is a mild service activity taken onto the car to obtain the desired combustion engine category. This combustion engine tune-up is done in order to reach the engine condition with maximum power, efficient in fuel consumption, and by the emissions level thresholds [1], [2].

The desired category of the combustion engine is the complete combustion category, in which case there is a balance between airflow, ignition, and fuel [3], [4]. On the other hand, the category of incomplete combustion is the opposite. To achieve this entire combustion engine category requires a definite indicator which is understandable by the mechanic during the tune up process.

The tune-up process of a car combustion engine with an injection system is carried out by a mechanic using diagnostic tool often called the engine scanner unit. This system can detect and simultaneously assist the process of the combustion engine tune-up in setting the fuel amount, air, and ignition of the vehicle. Engine scanner unit works based

on the diagnostic result of installed sensor data in the vehicle exhaust emissions channel integrated with the Engine Control Unit (ECU) [5]. This engine scanner is mounted on the connector as an interface system, and only available in the car injection system.

However, the tune-up of the car combustion engine carburetor system is performed manually, and based on the mechanic' experience. Here, there is no definite indicator used whether the desired combustion engine conditions are. Identification of combustion engine conditions through exhaust emissions is required as an indicator aid for the mechanic during the tune-up process for both cars carburetor system and injection system. The work of this system is based on the content of elements and compounds presented in the exhaust emissions in determining the combustion engine category. There are several elements and compounds in motor vehicle exhaust emissions that will determine the category of the combustion engine. In the exhaust emissions of the gasoline-fueled vehicle, the most significant roles in determining the combustion engine category are carbon monoxide (CO), carbon dioxide (CO₂), hydrocarbon (HC) and oxygen (O₂), as shown in Table 1 [5]-[7].

The magnitude value of each detected element and gas compound will differ between the complete combustion category and the incomplete one [7]. Therefore, this study aims to develop a system that is capable of identifying the combustion category on gasoline and *Pertalite*-fueled engine cars by comparing the data pattern of exhaust emissions reference with the detection result using the Sum Square Error Method (SSE).

TABLE I
THE CONDITION AND THE TYPE OF COMBUSTION ENGINE.

Elements and Gas compounds				Engine Combustion Conditions
CO	CO2	HC	O2	
H	L	H	H	Incomplete
H	L	H	L	Incomplete
L	L	L	H	Incomplete
L	H	L	H	Incomplete
H	L	M	H	Incomplete
H	H	H	H	Incomplete
L	L	H	H	Incomplete
L	H	L	L	Complete

H=High, L= Low, M= Medium

Based on Table 1, the complete combustion engine has a low level of HC and CO, a high level of CO2 and a low level of O2. It also produces exhaust emissions levels by the standard limit of allowed exhaust emissions. However, in Indonesia, based on the Minister of Environment Decree, No. 5, the year 2005 for gasoline-fueled motorcycles, the maximum level for CO is 5.5% and for HC is 2400 part per million (ppm) [8].

The levels of elements and gas compounds presented in the air can be detected by using electronic sensor components. The work of this sensor is based on the resistance changes on sensitive sensor component against the changes on elements and compounds in the air. With such a voltage value, it will represent the level of elements and compounds presented in the exhaust emissions [9]–[13]. The sensor needs response time to detect all the elements and compounds in the air maximally. As a result, there is a fluctuating change within a particular time frame in the form of the signal in the time domain.

The significant process in digital signal processing is to analyze an input or output signal in order to measure the characteristics of a particular physical system of signals. The synthesis and analysis process in the time domain requires a reasonably long analysis by involving the function derivatives, which can lead to inaccuracy on the analysis results. The signals synthesis and analysis will be more accessible to be performed in the frequency domain, concerning the most determining quantity of a signal is the frequency. Therefore, to work on the frequency domain, it requires an appropriate formulation so that the process of signal manipulation is by reality. One of the techniques used in analyzing the signals is to transform (to alter) the signal which is originally analog signal into a discrete one within a time domain, then converts it into the frequency domain.

Taken into account, the Fourier Transform is a transformation model that decomposes a spatial domain signal or time domain signal into a frequency domain signal. By using the Fourier transform, the signal can be seen as an object in the frequency domain while pattern data is one of

the ways in showing the characteristics or certain characteristics of indexed information from time to time. The data pattern is contained of information related to the desired condition within a specified time range [14]. The similarity between the 2 data can be carried out by calculating the margin value between the two of them. One of the methods applied is the Sum Square Error (SSE). The SSE method will calculate the difference in reference data with the data being tested. The smaller the SSE value, the more likely or similar the data will be [15]. Following is the SSE formula. Here is the SSE formula.

$$SSE = \sum_{i=0}^{i=n} (xi - yi)^2 \quad (1)$$

Where,

SSE is the sum of the error squared values,
xi value of magnitude to i of reference data,
yi value of magnitude to i of test data.

II. THE MATERIAL AND METHOD

Exhaust emissions are the residual produced during the combustion process inside the internal and external combustion engine discharging through an engine exhaust system. Gasoline-fueled car exhaust emissions contain several dominant elements and compounds such as HC, CO and CO2 and O2 [1], [2], [16]. These gas elements and compounds significantly affect engine performance. Excessive exhaust emissions indicate fuel wastage, resulting in an incomplete combustion engine.

Electronic fuel injection engine utilizes electronics systems to automatically regulate the airflow, fuel and ignition systems for complete combustion condition. It is proven by the lower level of exhaust emissions and it's environmentally friendly [16], [17]. On the other hand, the engine with carburetor system, setting system, air flow regulation system, fuel, and ignition was still carried out mechanically or electromechanically in order to get complete combustion category. To detect the elements and compounds contained in exhaust emissions, several sensors were used such as the O2 gas sensor using KE-50, CO2 using MG 811, CO using MQ 7 and HC using TGS 2201 [12], [13]. Then, the sensor component was assembled with electronics components as a signal conditioner, as seen in Figure 1.

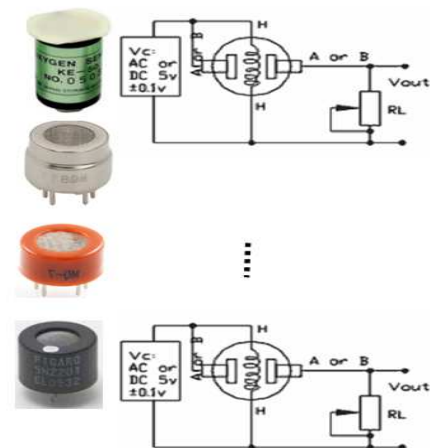

Fig. 1 O2, CO2, CO and HC sensor series [12], [13].

Then continued to signal processor consisting of an analog data reading process with certain sampling as viewed in Fig. 2.

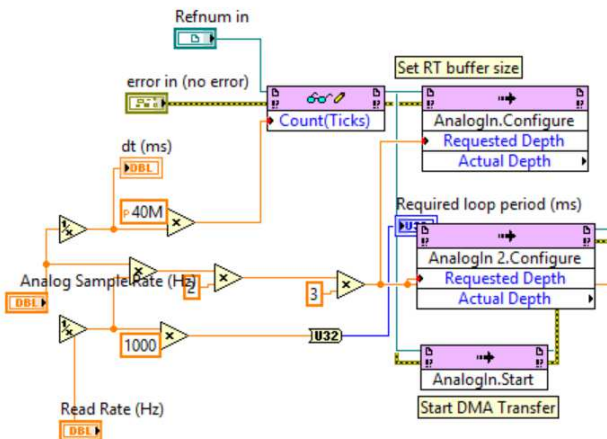

Fig. 2 Multi-sensor data reading program

The next step was Fast Fourier Transform (FFT) and was conducted to change the sensor detection data of the time domain into the frequency domain with certain magnitude values, as shown in Fig. 3. Stages of making data patterns were to get a unique pattern characterizing combustion engine category. The data pattern was obtained from the FFT process by choosing unique frequency characterizing this combustion engine category. Afterward, the result was taken as a reference data pattern. The identification process was done by comparing the occurring error value between the detection data pattern and reference data pattern utilizing the Sum Square Error (SSE) method. The system final result would display the decision whether it was the complete combustion engine category or the incomplete one.

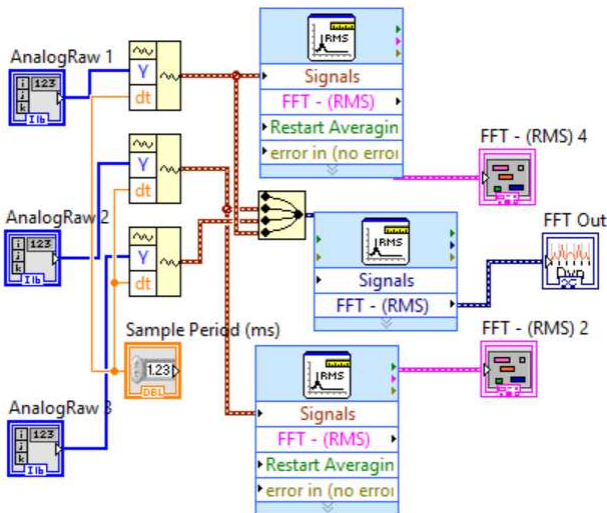

Fig. 3 FFT Process Program

Figure 4 below shows the graphics program in identifying and comparing SSE value.

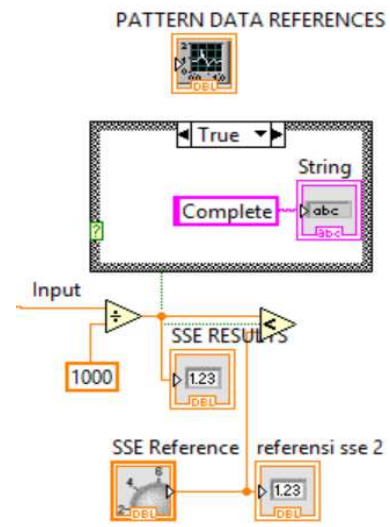

Fig. 4 SSE Program for Identification

Here, Figure 5 views the overall block diagram of the program.

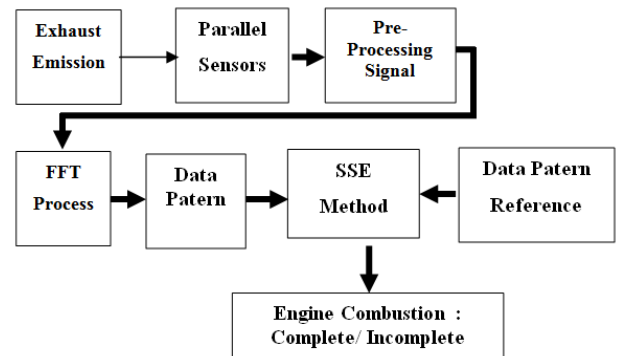

Fig. 5 The overall system program

Figure 6 illustrates the interface between the user and the system in the virtual instrument format.

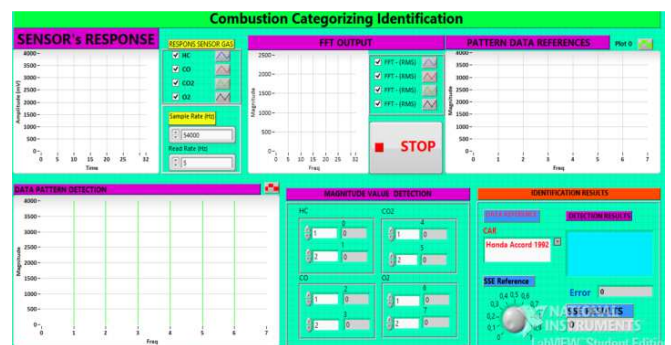

Fig. 6 Virtual Instrument system using a LabVIEW program

The design of the system made in this study implemented hardware and software taken from National Instruments and other electronics components. The hardware used was Field Programmable Gate Array Logic (FPGA) myRIO. Meanwhile, the software used for FPGA myRIO programming was LabVIEW, which was supported by the available libraries [18], [19].

This system was an electronic nose (e-nose) consisting of gas multi-sensor and integrated signal processing in an embedded system, and a PC or laptop as a display system. The testings had been done on certain types of car brands such as Toyota, Honda, Suzuki, Nissan, Hyundai, KIA and Daihatsu, the gasoline/*Pertalite*-fueled with carburetor and injection systems from different manufacturing years.

III. RESULTS AND DISCUSSION

The system was an embedded one composed of an input system in a multi-sensor and a primary multi-sensor. The sensor used was consisted of KE 50 sensor for O₂, MG 811 sensor for CO₂, MQ 7 sensor for CO and TGS 2201 sensor for HC. The signal conditioning circuit was the interface between the multi-sensor and the main system. Regardless, this main system consisted of an input integration system, FFT process, pattern making, identification system, and data reference. Hence, it was designed to be integrated on the MyRio FPGA module of the National Instrument. Meanwhile, the output display system utilized Laptop or Personal Computer (PC), as shown in Figure 7 for the system made. Here, the object of this study was the exhaust emissions of gasoline and *Pertalite*-fueled car with carburetor and injection systems.



Fig. 7 Overall system integration

A. Multi-sensor Response Testing Result on Exhaust Emissions Level.

The purpose of this testing was in order to obtain the response format of each sensor onto the level of elements and compounds presenting in the exhaust emissions. These testing were carried out on cars with both complete and incomplete combustion engine category. Complete combustion category car was a car that had been tuned up by a mechanic and in contrast to incomplete combustion one where it had yet undergone this tuning up and was ascertained by a mechanic. The testing was performed for 30 times on each type of the car in a certain time range or where no more exhaust emissions presented in the sensor room.

Figure 8 and Figure 9 show a multi-sensor response for a gasoline-fueled car with a carburetor system of both incomplete and complete combustion category.

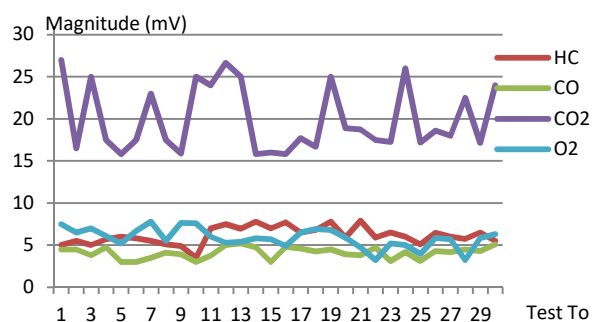

Fig. 8 Multi-sensor response of a gasoline-fueled and car carburetor system with incomplete combustion

The mean value for each sensor; HC = 4.02, CO = 2.25, CO₂ = 14.69 and O₂ = 2.09.

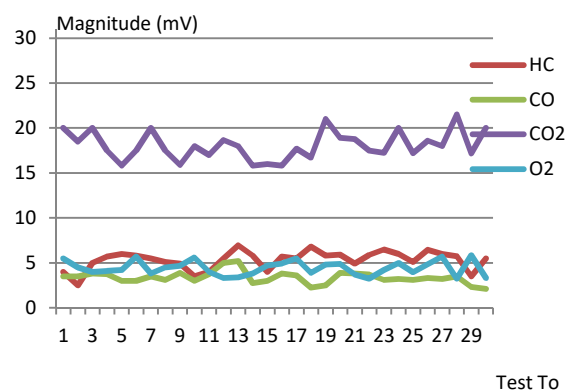

Fig. 9 Multi-sensor response of a gasoline-fueled and car carburetor system with complete combustion

Based on the sensor response result in Fig. 9, the mean value for each sensor was HC = 3.86, CO = 1.87, CO₂ = 12.67 and O₂ = 1.89. Figure 10 and 11 illustrate a multi-sensor response for a *Pertalite*-fueled and car carburetor system with both complete and incomplete combustion category system.

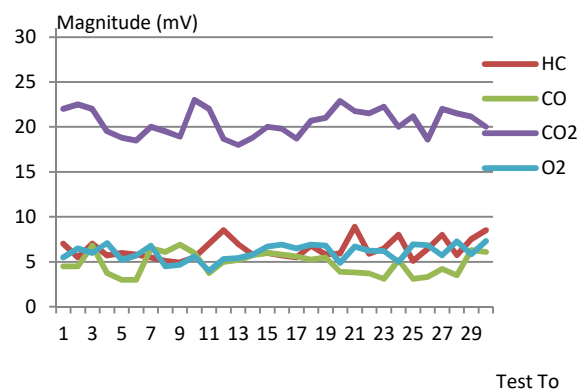

Fig. 10 Multi-sensor response of a *Pertalite*-fueled and car carburetor system with incomplete combustion

The mean value for each sensor was HC = 4.02, CO = 2.25, CO₂ = 14.69 and O₂ = 2.09.

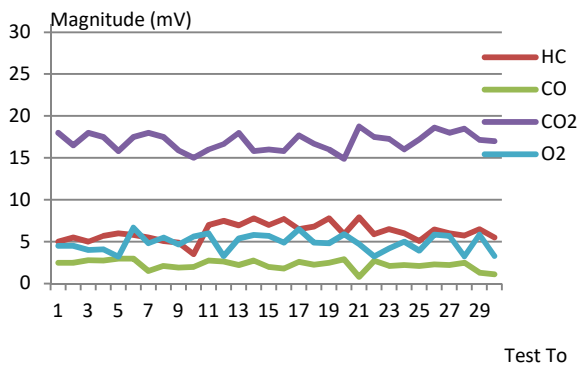

Fig. 11 Multi-sensor response of a *Peralite*-fueled and car carburetor system with complete combustion

Based on the sensor response result in Fig. 11, the mean value for each sensor was HC = 3.86, CO = 1.87, CO₂ = 12.67 and O₂ = 1.89. Figure 8 and 10 show the differences in magnitude sensors between gasoline-fueled and *Peralite*-fueled cars. For gasoline-fueled cars, there were fluctuations in CO₂ value changes which was relatively high compared to *Peralite*-fueled ones. In contrast, Figure 9 and 11 show the value changes of each sensor for complete combustion engine conditions where the fluctuations of these changes are relatively smaller in the *Peralite*-fueled cars than the gasoline-fueled ones.

Furthermore, a multi-sensor response test for the gasoline-fueled car injection system with an incomplete and complete combustion system was performed.

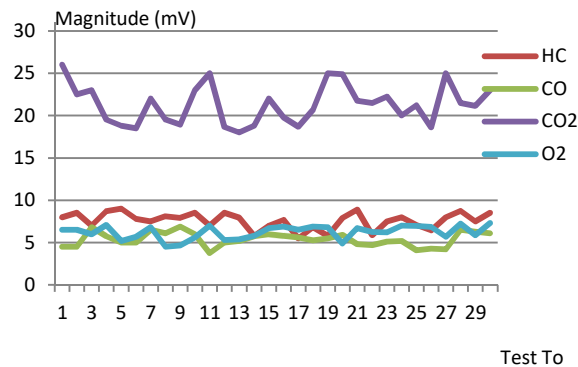

Fig. 12 Multi-sensor response of a gasoline-fueled and car injection system with incomplete combustion

The mean value for each of the response was HC = 3.93, CO = 3.55, CO₂ = 15.7 and O₂ = 3.96.

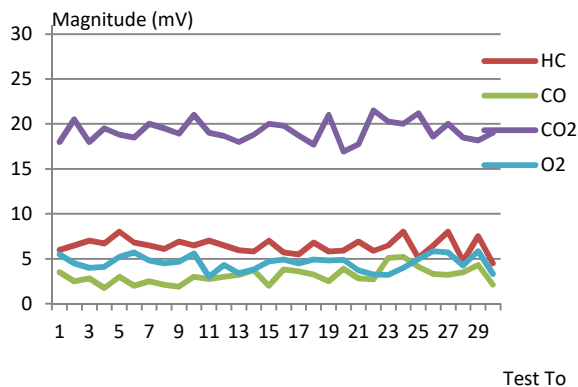

Fig. 13 Multi-sensor response of a gasoline-fueled and car injection system with complete combustion

Based on the sensor response result in Fig. 13, the mean value for each sensor was HC = 3.54, CO = 1.79, CO₂ = 12.92 and O₂ = 1.72. Figure 12 and 13 view multi-sensor response for a *Peralite*-fueled car and injection system with both complete and incomplete combustion category system.

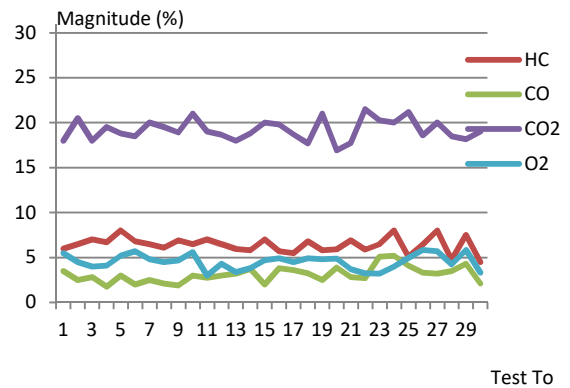

Fig. 14 Multi-sensor response of a gasoline-fueled and car injection system with incomplete combustion

Figure 14 shows the mean value of HC = 3.86, CO = 2.32, CO₂ = 13.32 and O₂ = 2.72.

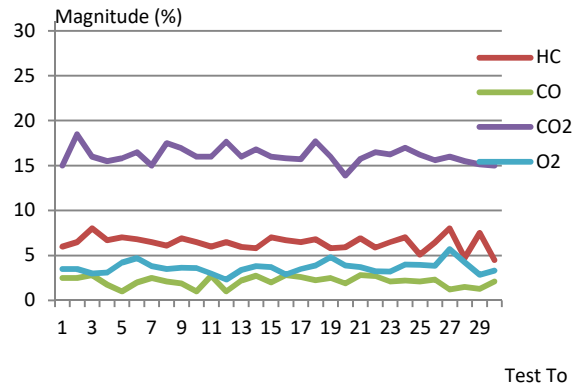

Fig. 15 Multi-sensor response of a *Peralite*-fueled and car injection system with complete combustion

Taken from Figure 15 the mean value was HC = 3.16; CO = 1.69; CO₂ = 10.7 and O₂ = 1.39. When the complete combustion engine conditions occurred, the magnitude value of each sensor for a car injection system was relatively low compared to the car carburetor system. This shows that the level of exhaust emissions for the car injection system is better than a car carburetor system. The magnitude difference between the complete combustion engine condition and the incomplete one resulted in differences in magnitude values and the displayed data patterns.

B. The Making of Reference Data Pattern

The identification process of the combustion engine category was done by comparing the detected data pattern with the reference data pattern. The later is a comparative data pattern for both categories of complete and incomplete combustion. Figure 16 shows reference data patterns for *Peralite*-fueled *Honda Mobilio* car manufactured in 2015. This pattern referred to the complete combustion category data pattern.

There were eight magnitude data patterns which were the extracts characteristic of the complete combustion engine category. The reference data pattern was obtained from the FFT process of the sensor signal in the frequency domain. Each magnitude showed the magnitude of the element content and the detected compound. Figure 16 and 17 are patterns of data used as reference data. Here, the reference data is comparative data as a result of the identification process. Comparison of reference data with detection data yields the difference value of the error value.

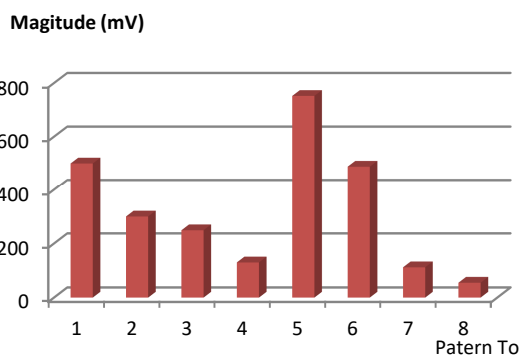

Fig. 16 Reference data pattern of *Peralite-fueled Honda Mobilio* Car manufactured in 2015

Figure 17 shows the reference data format for some types or brands of cars in Indonesia.

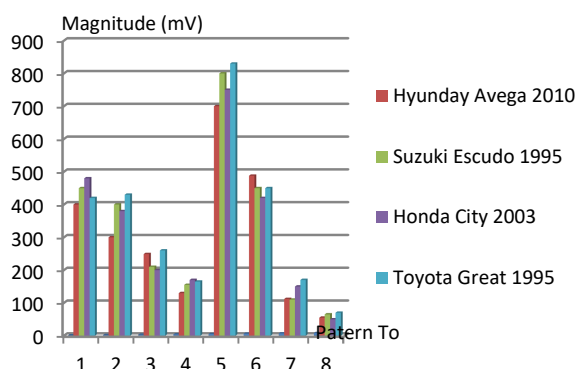

Fig. 17 Reference data pattern of complete combustion on several car brands

This reference data pattern was stored in the system as a database, and selected according to the type of car to be tested. Then, the magnitude value of this reference pattern was compared to the magnitude value of the identification data pattern to get the SSE value.

C. The Making of Reference Value Error

Then it continued to set out SSE reference value in order to determine either it was a complete or incomplete combustion category. Table 3 shows the decision results of the combustion engine category based on the variation of SSE reference value changes on *Honda Mobilio* manufactured in 2015.

TABLE II
THE DECISION RESULT OF COMBUSTION CATEGORY BASED ON VARIATION OF SSE REFERENCE VALUE ERROR OF *HONDA MOBILIO* MANUFACTURED IN 2015.

SSE Value	Decision Result
0.40	Incomplete
0.30	Incomplete
0.20	Incomplete
0.10	Complete
0.09	Complete
0.08	Complete

From the testing data in Table 2, the SSE reference value error was set to maximum at 0.1. Subsequently, the reference data pattern and SSE value error determination were made for several vehicle types as shown in Table 3.

TABLE III
DETERMINING THE CAR SSE VALUE WITH DIFFERENT YEARS OF MANUFACTURE

Type of car	SSE value error
Hyundai Avega 2010	0,15
Toyota Corolla 1995	0,2
Suzuki Escudo 1995	0,19
Honda City 2003	0,18
Honda Mobilio 2015	0,1
Toyota Avanza 2014	0,12
Daihatsu Xenia 2010	0,15
Nissan Grand Livina 2015	0,14
Datsun Go Panca 2016	0,13
KIA Picanto 2016	0,16

D. Identification Test of Engine Combustion Category

The identification test was carried out onto cars which were their combustion category had been classified already. It was intended to determine the system ability in identifying the combustion engine category. This testing was conducted to cars which had been recognized having both complete and incomplete combustion category. The identification test of the complete combustion category can be viewed in Table 4.

TABLE IV
IDENTIFICATION TESTING RESULT OF CAR WITH COMPLETE COMBUSTION CATEGORY

Number of Tests	Identification System Result
1	Complete
2	Complete
3	Complete
4	Incomplete
5	Complete
6	Complete
7	Complete
8	Complete
9	Complete
10	Complete
11	Complete
12	Complete
13	Complete
14	Complete
15	Complete
16	Complete

17	Complete
18	Complete
19	Complete
20	Complete
21	Complete
22	Complete
23	Complete
24	Complete
25	Incomplete
26	Complete
24	Complete
28	Incomplete
29	Complete
30	Incomplete

From the testing result seen in Table 4, the success rate of the system in identifying the complete combustion category was 87%. Table 5 is the identification test of incomplete combustion. From 30 times of trial test, a 77% success rate of system identification was obtained.

The next test was the identification test of the combustion engine category on several cars that yet had their combustion category. The testing subject was gasoline or *Pertalite*-fueled car with carburetor and injection systems. The testing was carried out simultaneously on the identification of the system made and identification taken from the mechanic with the aids of an engine scanner unit.

TABLE V
IDENTIFICATION TESTING RESULT OF CAR WITH INCOMPLETE COMBUSTION CATEGORY

Number of Tests	Identification System Result
1	Complete
2	Incomplete
3	Complete
4	Incomplete
5	Complete
6	Complete
7	Complete
8	Complete
9	Complete
10	Complete
11	Complete
12	Complete
13	Incomplete
14	Complete
15	Complete
16	Complete
17	Complete
18	Complete
19	Complete
20	Complete
21	Complete
22	Complete
23	Complete
24	Incomplete
25	Incomplete
26	Complete
24	Complete
28	Incomplete
29	Complete
30	Incomplete

TABLE VI
IDENTIFICATION TESTING RESULT OF SYSTEM AND MECHANIC ON UNKNOWN COMBUSTION CATEGORY

No	Type of Car	Identification System Result	Identification by A Mechanic
1	Injection System	Complete	Complete
2	Injection System	Incomplete	Incomplete
3	Carburetor System	Complete	Incomplete
4	Carburetor System	Incomplete	Complete
5	Carburetor System	Complete	Complete
6	Injection System	Incomplete	Incomplete
7	Carburetor System	Incomplete	Incomplete
8	Carburetor System	Incomplete	Complete
9	Injection System	Complete	Complete
10	Carburetor System	Incomplete	Incomplete

Table 6 illustrates the comparison between the identification test result derived from the system made and the one from the mechanic. Hence there was a difference which was equal to 30%. Thus, this system was a success in identifying the combustion engine category which was equal to 70%. During the identification process, the mechanic utilized engine scanner unit as an aid in detecting the category of car combustion engine injection system, and in another hand used the manual way for the car carburetor system.

IV. CONCLUSION

Referring to the results and analysis data conducted by this study, it can be summarized as follows: Multi-sensor response is capable of displaying the role of elements and compounds level in determining the category of the combustion engine. There is a magnitude value difference in the obtained data pattern between complete and the incomplete combustion category on some cars with different brands, manufactured years, fuel flow system and type of fuel used. As a consequence, there is a difference in maximum error value in deciding on each tested car to get the desired identification results.

The system accuracy level in identifying the complete combustion category was 87%, and the incomplete combustion category was 77%. Besides that, there is a difference in the identification result of the combustion engine category by 30% between the identification results of the developed system with the result conducted by the mechanic.

ACKNOWLEDGMENT

This research was granted by the Ministry of Research Technology, and Higher Education Republic of Indonesia (Kemenristek DIKTI). The writer would like to express deepest gratitude and appreciation to Kemenristek DIKTI,

and Research and Social Service Unit (P3M) Politeknik Negeri Padang for their welcome cooperation.

REFERENCES

- [1] Han Bing-yuan, Bei Shao-yi, Zhao Jing-bo, Feng Jun-Ping, " Effect on gasoline engine emission characteristics of variable composition oxygen-enriched intake air", Volume 10 Issue 24, BTAIJ, page 15414-15421, 2014.
- [2] Gerhard Knothe, Christopher A. Sharp, and Thomas W. Ryan http://id.wikipedia.org/wiki/exhaust_emissions. Access on March 29th 2017.
- [3] Nidhi Arora, Swati Mehta, " Air fuel ratio detector corrector for combustion engines using adaptive neuro-fuzzy networks, " Vol.3, No.2, IJOCTA, page.85-97, 2013.
- [4] Ranbir Singh, " Performance and Exhaust Gas Emissions Analysis of Direct Injection Cng-Diesel Dual Fuel Engine", Vol. 4 No.03, IJEST, page 833-846, 2012.
- [5] T. Polonec, I. Janoško, " Improving performance parameters of the combustion engine for racing purposes", Vol. 60, No. 3, Res. Agr. Eng, page 83-91, 2014.
- [6] Van, Basshuysen Richard, and Fred Schäfer. Internal Combustion Engine Handbook: Basics, Components, Systems, and Perspectives. Warrendale, PA: SAE International, 2004.
- [7] Andrizal, Rivanol Chadry, Budhi Bachtiar, "Detection Combustion Data Pattern on Gasoline Fuel Motorcycle with Carburetor System", Vol 6, No 1, IJASEIT, page 107-111, 2016.
- [8] Mohd. Gempur Adnan, "Ambang batas emisi gas buang kendaraan bermotor lama" Peraturan Menteri Negara Lingkungan no 5 tahun 2006.
- [9] A. D. Wilson and M. Baitto, " Advances in Electronic-nose technologies developed for biomedical applications," Sensors, page 1105-1176, 2011.
- [10] Rupali V. Chothe, Sunita P. Ugale, " E-Nose for gas detection at vehicle exhaust Using supervised learning algorithm" Volume 1, Issue 4, IJETTS page 145-149, 2012.
- [11] Ahmed Soliman, Prabhu J.Jackson, Giorgio Rizzoni and Prabir Dutta, "A sensor array for control of engine exhaust after-treatment system", skoge/prost/proceedings/ifac 2005.
- [12] Figaro Group, "Product Information Figaro OxygenSensor SK-25F", <http://www.figaro.com/>, 2014.
- [13] Hanwei electronics, mg-811 data sheet, <http://www.hwsensor.com>. Accessed on March 5th 2014.
- [14] Henrick, A.Nadia, Andrizal, " Identifying Tuberculosis through Exhaled Breath by Using Field Programmable Gate Array (FPGA) myRIO", Vol 3 No 6, JOACE, page 470-474, 2015.
- [15] Sam Hopkins, Jonathan Shi, David Steurer, " Tensor principal component analysis via sum-of-squares proofs", vol 40, Workshop and Conference Proceedings, page 1-51, 2015.
- [16] Keith Moore, National instruments application notes, " Testing Automotive Exhaust Emissions, ".
- [17] Joko Winarno, "Study of exhaust emissions of petrol-engined vehicles in various brands of vehicles and the year of manufacture", published by the Journal of Engineering, Faculty of Engineering, University of Jogjakarta Janabadra, Volume 4 Number 1 in 2014.
- [18] National Instruments, "NI myRIO Design Real Time System, [fast ftp://ftp.ni.com/pub/.../myrio_do_engineering_nid14.pdf](fastftp://ftp.ni.com/pub/.../myrio_do_engineering_nid14.pdf), 2014.
- [19] National Instrument, "Getting Started With LabVIEW FPGA", www.ni.com/Tutorials, 2016.